



**NAPCO**

**OPERATING AND INSTALLATION INSTRUCTIONS**

**MAGNUM ALERT-900  
ALARM CONTROL CENTER  
and DIGITAL COMMUNICATOR**

**TABLE OF CONTENTS**

<u>Section</u>	<u>Page</u>
1. HOW TO USE THIS MANUAL . . . . .	1-1
GENERAL SYSTEM DESCRIPTION . . . . .	-1
FEATURES . . . . .	-1
PROTECTION ZONES . . . . .	-1
KEYPAD . . . . .	-2
COMMUNICATOR . . . . .	-3
2. PROM PROGRAMMING INFORMATION . . . . .	2-1
PROGRAMMING MATERIALS . . . . .	-1
PROGRAMMING STEPS . . . . .	-1
PROGRAMMING RECORD SHEET . . . . .	-3
GLOSSARY . . . . .	-5
PROGRAMMING TROUBLESHOOTING GUIDE . . . . .	-25
PROGRAMMING RECORD SHEET EXAMPLES . . . . .	-30
3. KEYPAD OPERATION . . . . .	3-1
INDICATORS . . . . .	-2
KEYS . . . . .	-2
HOLD-DOWN FUNCTIONS . . . . .	-3
DAILY OPERATION . . . . .	-7
4. INSTALLATION . . . . .	4-1
CONTROL-CENTER MOUNTING . . . . .	-1
GROUNDING . . . . .	-1
TYPICAL FIRE INSTALLATION . . . . .	-1
SELECTING WIRING FEATURES . . . . .	-1
WIRING DIAGRAM . . . . .	-2
TERMINAL CONNECTIONS . . . . .	-3
SPECIFICATIONS . . . . .	-12
POWER-UP SEQUENCE . . . . .	-12
TESTING PROCEDURE . . . . .	-13
FAMILIARIZING THE END-USER WITH THE SYSTEM . . . . .	-14
WIRING TROUBLESHOOTING GUIDE . . . . .	-15
KEYPAD MOUNTING . . . . .	-23
5. INDEX . . . . .	5-1

(SEE PAGE 1-3 FOR A SUMMARY OF CHANGES FROM PREVIOUS EDITION)

UL LISTED: HOUSEHOLD FIRE AND BURGLARY WARNING SYSTEM CONTROL UNIT

(c) NAPCO 1985

WI320J 10/91

## HOW TO USE THIS MANUAL

Chapter 1 gives a general system description of the components supplied with each system, followed by a list of the various built-in and optionally programmable features.

Chapter 2 (PROM PROGRAMMING INFORMATION, Programming Record Sheet and Glossary) begins with a general discussion of programming materials and general programming steps, contains a Programming Record Sheet, followed by a glossary, which describes each feature and specifies how to program each feature that requires programming.

Chapter 3 (KEYPAD OPERATION) explains the purpose of keypad features, and the steps for using each function key. Read this section before installing and testing. Use Hold-Down Functions and Daily-Operation procedure when troubleshooting.

Chapter 4 (INSTALLATION) gives instructions for mounting, wiring (in terminal-number order) and power-up instructions, a specifications list, testing procedure and troubleshooting guide for installation and service.

Use the INDEX (Chapter 5) to locate features, programming, operation and wiring information by name, PROM location, and terminal number, and to find explanations of special terms.

## GENERAL SYSTEM DESCRIPTION

The MAGNUM ALERT-900 is an advanced microcomputer-based, twelve-zone mercantile and residential control center. Each system is contained within a wall-mounted cabinet, and equipped with an integral communicator, a multifunction digital keypad, a transformer, a battery and a partially-programmed PROM.

The keypad has keys for digital code arming/disarming, panic alarm and selective zone shunting. Keypad indicators provide system and individual zone status information. Numerical keys have secondary functions, providing conveniently located aids such as battery and central station condition testing, entry delay cancellation, selective zone shunting, Day-Zone trouble indication, and reset for fire detectors, alarm and trouble. (See the FEATURES section of this chapter and the KEYPAD OPERATION chapter for more detailed information.)

The PROM is programmed for the particular installation, and then gives the alarm system its local and communication features. (See the FEATURES section of this chapter for a list of programmable functions, and Chapter 2 for programming instructions.)

## FEATURES

### PROTECTION ZONES

#### FACTORY-SUPPLIED ZONE FEATURES

- Nine Burglary Zones, one a dedicated Exit/Entry Zone with delay.
- Two 24-Hour Auxiliary Zones with 50-millisecond detection response.
- One Supervisory Zone, generally used for fire protection, capable of reporting both trouble and alarm conditions. May alternatively be used to monitor such installation conditions as temperature or essential equipment functioning.
- All zones are end-of-line resistor supervised:
  - › Each can contain a combination of normally-closed and normally-open contacts.
- Exit/Entry, 24-Hour Auxiliary and Fire (Supervisory) Zones preselected for Auto-Reset.

## PROGRAMMABLE ZONE OPTIONS

- Exit/Entry Zone options:
  - > Adjustable exit/entry delays.
  - > Start Exit Delay After Closing Ringback feature checks that central station is responding properly before exit delay can start, or allows exit delay to be started by pressing a keypad button.
  - > Detection on Burglary Zones with devices in the exit/entry path can be delayed during the entry and exit periods.
- Burglary Zone options:
  - > Priority, individual and group manual shunt, 24-Hour Protection and Auto-Reset available on Burglary Zones. Preprogrammed Auto-Shunt may be cancelled.
  - > 750-millisecond detection response time selectable down to 50 or 7 milliseconds.
  - > Day Zone supervision trouble indication can be selected for Burglary Zones. Audible indication is optional.
- Fire (Supervisory) Zone options:
  - > A pair of output relay contacts can be program-selected to reset latched smoke detectors when cleared of smoke.
  - > Fire alarm can automatically time out after program-selected period.
  - > Supervisory Zone alarm can pulse.
- Alarm output options:
  - > Three possible outputs:
    - One integrated burglary/fire (supervisory) siren driver. Capable of 12Vdc output for driving bell by jumper selection.
    - Two sets of output relay contacts that may be isolated by jumper-selection.
  - > Separate automatic alarm time out period optionally programmed for each alarm output.
  - > Automatic battery/alarm test can be programmed to pulse siren when the system is armed.

## KEYPAD

### FACTORY-SUPPLIED KEYPAD FUNCTIONS

- Indicators:
  - > LEDs indicate when: system is armed, one or more burglary alarms has occurred, zones are in trouble, zones are manually shunted, instant protection is in effect, or ac power has failed. Digital readout identifies alarm, trouble, and shunted zones by number.  
LEDs and Mini-Sounder distinguish between Fire (Supervisory) Zone alarm and trouble.
- Keys:
  - > Numerical keys provide arming/disarming with up to eight user codes of 4 digits each.
  - > User can program from keypad up to 8 different arm/disarm codes, and a 9th code which may activate an electric door lock.
  - > Test function activates alarm device from the standby battery.
  - > User can cancel exit/entry delay while premises are occupied.
  - > Zone identification obtained by pressing a hold-down function key.
  - > "Fault Find" aid reduces response time on Zones 1 through 8 to 7 milliseconds, and provides Mini-Sounder indication when a zone (including fire trouble) restores to normal. This aids an installer or service person in checking for swingers, and assists the user in correcting such trouble conditions as open windows.
  - > Single button resets keypad Fire (Supervisory) Zone indicators, latched detectors, and Day-Zone trouble indication.
- Keypad [\*] and [#] keys can activate a panic alarm on one 24-Hour Auxiliary Zone.

#### PROGRAMMABLE KEYPAD FUNCTIONS

- Mini-Sounder can indicate dial-tone detection success or failure.
- If exit delay waits for closing ringback, but central station failure prevents ringback, the user can press a key to manually start exit delay.
- The user can manually shunt zones individually and/or by group, and press a key to request digital display of shunted zone numbers. Shunting is cleared on disarming.
- Ambush code can trigger silent communicator report if an intruder forces the user to disarm.
- System can be armed/disarmed with a fallback code following an extended power outage.

#### COMMUNICATOR

##### FACTORY-SUPPLIED FEATURES

- Integrated digital communicator has true dial-tone detection, double-pole line seizure and anti-jam.
- Multiple reporting alerts central station of all events occurring.

##### PROGRAMMABLE COMMUNICATOR OPTIONS

- Two telephone numbers, receiver and data formats can be accessed. A single master PROM is compatible with all popular receivers.
- Alarm/restore reporting identifies individual zones.
- Two-digit event codes and 4-digit subscriber codes can be programmed for receivers that accept these data formats.
- Opening/closing reports distinguish between arm/disarm codes. Shunted and latched alarm zones can be identified on closing.
- Low-battery condition, ac failure, Day Supervision and Fire Zone (Supervisory) trouble can be reported.
- Abort Delay available.
- Rotary or touch-tone dialing available. If touch tone is not successful, rotary can back up touch tone.

#### CHANGES FROM THE PREVIOUS EDITION

Summarized below are changes made to this manual since the previous edition.

- Front Cover: \* New addresses & Telephone Numbers  
\* TABLE OF CONTENTS updated (TYPICAL FIRE INSTALLATION and KEYPAD MOUNTING listed).
- Page 1-4: \* ORDERING INFORMATION revised (EOL1K added) and RECOMMENDED UL-LISTED DEVICES revised (Ademco Bell numbers corrected).
- Page 2-17: \* PANIC ALARM revised (Remote keypad panic switch wiring added).
- Page 2-18: \* PRIORITY WITH BYPASS text revised
- Page 3-3: \* Hold-Down Function 4: INSTANT PROTECTION (second paragraph revised -- "within 8 seconds" deleted).
- Page 3-8: \* ARMING Step (3) revised ("Arm within 8 seconds" deleted).
- Page 4-2: \* WIRING DIAGRAM revised (EOL1K added)
- Page 4-11: \* Fire, Burglary Lugs text revised.
- Page 4-23: \* KEYPAD MOUNTING added.
- Page 4-24: \* KEYPAD MOUNTING TEMPLATE added.
- Page 4-25: \* WIRING LEGEND added.
- Page 5-1, -2 \* INDEX revised.

## ORDERING INFORMATION

Starred items (\*) are UL-Listed Accessories.

MA-900	12-zone, 12-volt alarm control center with integrated communicator and siren driver; white keypad; transformer; PROM; and battery.
RP 1009*	Remote arming station with dual-function keys, light, digital display and Mini-Sounder indication, panic and shunt. White is standard; RP-1009B is brown; RP-1009I (white only) is illuminated.
RP-1009B*	
RP-1009I*	
RP-1009L*	Remote Keyswitch Arming Station with light, digital display and Mini-Sounder indication (less keyswitch).
RPB-1	Surface Mounting Backplate for RP-1009
RPB-2	Double Gang Box for RP-1009 or RP-1009L
TPS-2	Tamper Switches, set of 2
RBAT6	Rechargeable Battery, 6AH, 12Vdc
RBAT-H1*	Dual Battery Harness
TRF-11	Transformer, 16.5Vac, 40VA Class 2
EOL1K	Fire Circuit End-of-Line Resistor Assembly, 1k
FT-279*	Fire Circuit End-of-Line Relay/Resistor Supervisory Module
GSM-400	Ground-Start Module
M-278*	Line-Reversal Module
SNP-428	Mini-Sounder
PF150A	Programming Record Sheets, 100/pad
SR900	Feature Selection Guide
PRO-410M	PROM Programmer
DD493	Partially-Programmed PROM
DD493BNK	Blank PROM
TM-900*	Timer Module
LW-900*	Long-Range Wireless Interface
OI102	Instruction Manual
A-191	Consumer Brochure, Residential
A-191COM	Consumer Brochure, Commercial
A-192A	Dealer Brochure

## RECOMMENDED UL LISTED DEVICES

Bells:	Ademco AB8-12, AB10-12 Amseco MBL-8/12V, -10/12V
Speakers:	Ademco 713 Atlas Sound VT-158U
Smoke Detectors:	BRK 1812, 7 maximum 2812TH 7 maximum Pyrotector 300942, 30 maximum Pyrotector 301942, 30 maximum Pyrotector 305942, 30 maximum

## PROM PROGRAMMING INFORMATION

### PROGRAMMING MATERIALS

**SUBSCRIBER PROM** - The partially-programmed (DD493) PROM (integrated circuit chip) supplied with the control center becomes a subscriber PROM when programmed with the selected features and communicator information required for your installation. Programming for a specific installation is done on a Model PRO-410/410M PROM Programmer (Fig. 2-1). After programming, the subscriber PROM is plugged into the PROM socket on the control-center board.

**GLOSSARY** - Detailed programming instructions are in the Glossary portion of this section. Glossary items are listed in the order of name, not PROM location. (PROM locations for each item follow its name.) Item names which begin with letters are arranged alphabetically at the front of the Glossary; followed by names beginning with numbers, in numerical order. (The Index at the back of this manual lists PROM locations in numerical order and gives the Glossary item name for each.)

**PROGRAMMING RECORD SHEET** - A Programming Record Sheet is completed when planning features and communicator information to be programmed for the installation. After completion, the Programming Record Sheet is used to program the subscriber PROM, then saved as a permanent record for reference.

**FEATURE SELECTION GUIDE** - The Programming Record sheet can be inserted into the Feature Selection Guide, a "slide-rule" type of guide, to make feature selection easier and faster. The Feature Selection Guide for the MAGNUM ALERT-900, with instructions, is ordered separately and used again as often as necessary, to prepare Programming Record Sheets for different installations.

### PROGRAMMING STEPS

- (1) Call the central station for receiver format, data format, event codes, subscriber numbers, and telephone number. Two receiver descriptions and telephone numbers, and up to 6 subscriber identification numbers may be needed.
- (2) Complete the Programming Record Sheet. A Programming Record Sheet for the MA-900 is provided in the following portion of this section.

Select the feature desired by circling its location box(es). The Glossary explains what to write in boxes without preprinted feature entries. If a box has "FIXED" in it, and no location number, the feature named to the left of the box has already been selected for the zone or condition named above it. If a box is black, the feature named to the left of it cannot be selected for the zone or condition named above it.

- (3) To program the subscriber PROM, follow the instructions furnished with the PRO-410/410M programmer.

**NOTE.** It is not necessary to copy a master PROM onto the DD493 PROM supplied with your system. The DD493 PROM already has the master information preprogrammed on it. Plug the partially-programmed DD493 PROM into the socket of the programmer reserved for the Subscriber PROM (PRO-410) to be programmed.

**CAUTION:** Before attempting to alter preprogrammed data on Page 1, be sure that all Page-0 data in memory are erased (press [ERASE], then [EXECUTE]). Except for the Page-1 location being programmed, there should be nothing in memory. After programming Page 1, return the PAGE switch to [0] and clear the memory to continue programming.

- (4) Program any entries in the boxes from the Programming Record Sheet into matching locations. **NOTE:** When the PRO-410 Programmer is used, it may be necessary to precede entry numbers by the [PLUS] key to add to existing data entries.
- (5) Locate the Installation Record label (Fig. 2-1) packaged with the control center. Complete the Programmable Zone Features portion. Peel off the protective paper from the adhesive on the back and affix the label inside the control-center door (lower-left corner). This summary will be used by the installer to match wiring options to programmed features.

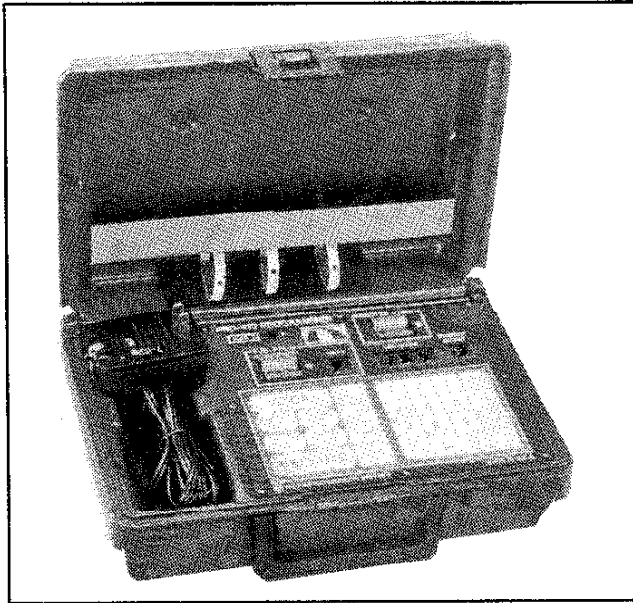

PRO-410 Programmer

MA900 INSTALLATION RECORD																																
Central Station Telephone: _____																																
Service: _____	Telephone: _____																															
Installer: _____	Date Installed: _____																															
<b>ALARM TIME</b> BURGLARY = _____ Min. FIRE = _____ Min. OUTPUT 1 = _____ Min. OUTPUT 2 = _____ Min. ENTRY DELAY TIME = _____ Secs. EXIT DELAY TIME = _____ Secs.		<b>PROGRAMMED ZONE FEATURES</b> <table border="1" style="width: 100%; border-collapse: collapse; text-align: center;"> <tr> <th>Day Zone</th> <th>Priority With Bypass</th> <th>Priority</th> <th>Non-Auto-Shunt</th> <th>Selective Shunt</th> <th>Group Shunt</th> <th>24 Hour Protection</th> <th>Auto-Reset</th> <th>Exit Entry Follower</th> <th>Abort Delay</th> <th>Burglary Output</th> <th>Output 1</th> <th>Output 2</th> <th>Loop Response 7 m. sec.</th> <th>Loop Response 30 m. sec.</th> </tr> <tr> <td> </td><td> </td><td> </td><td> </td><td> </td><td> </td><td> </td><td> </td><td> </td><td> </td><td> </td><td> </td><td> </td><td> </td><td> </td> </tr> </table>	Day Zone	Priority With Bypass	Priority	Non-Auto-Shunt	Selective Shunt	Group Shunt	24 Hour Protection	Auto-Reset	Exit Entry Follower	Abort Delay	Burglary Output	Output 1	Output 2	Loop Response 7 m. sec.	Loop Response 30 m. sec.															
Day Zone	Priority With Bypass	Priority	Non-Auto-Shunt	Selective Shunt	Group Shunt	24 Hour Protection	Auto-Reset	Exit Entry Follower	Abort Delay	Burglary Output	Output 1	Output 2	Loop Response 7 m. sec.	Loop Response 30 m. sec.																		
ZONE	AREA PROTECTED	ZONE DEVICES																														
1																																
2																																
3																																
4																																
5																																
6																																
7																																
8																																
EXIT/ENTRY																																
Aux-1 Panic																																
Aux-2 Ambush																																
Fire																																
SPECIAL NOTES: _____																																

Installation Record

SET (FOR MAGNUM ALERT-900)																																																																																
ZONE ONE	ZONE TWO	ZONE THREE	ZONE FOUR	ZONE FIVE	ZONE SIX	ZONE SEVEN	ZONE EIGHT	EXIT	Aux 1	Aux 2	Supp	Supp	Zone 1	Zone 2																																																																		
178	178	178	178	178	178	178	178	180	180	180	180	181	181	181																																																																		
1	2	4	8	1	2	4	8	1	2	4	8	1	2	4																																																																		
182	182	182	183	183	183	183	184	184	184	184	184	185	185	185																																																																		
1	2	4	8	1	2	4	8	1	2	4	8	1	2	4																																																																		
180 183 183																																																																																
1 4 8																																																																																
FEATURE SELECTION GUIDE (FOR MAGNUM ALERT-900)																																																																																
STANDARD CONTROL/COMMUNICATOR FEATURES																																																																																
ZONES																																																																																
LOCATION	ZONE ONE	ZONE TWO	ZONE THREE	ZONE FOUR	ZONE FIVE	ZONE SIX	ZONE SEVEN	ZONE EIGHT	EXIT	Aux 1	Aux 2	Supp	Supp	Zone 1																																																																		
ENTRY	1	2	4	8	1	2	4	8	1	2	4	8	1	2																																																																		
FEATURES																																																																																
-50 ms LOOP RESPONSE																																																																																
-7 ms LOOP RESPONSE																																																																																
-OUTPUT 2																																																																																
-OUTPUT 1																																																																																
-BURGLARY OUTPUT																																																																																
-ABORT DELAY																																																																																
-EXIT/ENTRY FOLLOWER																																																																																
-AUTO-RESET																																																																																
-24 HOUR PROTECTION																																																																																
-GROUP SHUNT																																																																																
-REFLECTIVE SHUNT																																																																																
-REMOVE AUTO-SHUNT																																																																																
-PRIORITY																																																																																
-PRIORITY WITH BYPASS																																																																																
-DAY ZONE																																																																																
-ZONE RESTORAL																																																																																
-CONTROL CENTER RESTORAL																																																																																
-REPORT ON ALARM/TROUBLE																																																																																
-SUPERVISORY OUTPUT TIME																																																																																
-EXIT/ENTRY DELAY TIME																																																																																
<table border="1" style="width: 100%; border-collapse: collapse; text-align: center;"> <tr> <th colspan="2">TIME SELECTOR CHART</th> <th colspan="3">EXIT DELAY TIME (IN SECONDS)</th> <th colspan="3">ENTRY DELAY TIME (IN SECONDS)</th> <th colspan="3">OUTPUT TIME (IN MINUTES)</th> </tr> <tr> <td>TIME</td><td>1st BOX</td><td>2nd BOX</td><td>1st BOX</td><td>2nd BOX</td><td>1st BOX</td><td>2nd BOX</td><td>1st BOX</td><td>2nd BOX</td><td>1st BOX</td><td>2nd BOX</td> </tr> <tr> <td>5</td><td>5</td><td>NONE</td><td> </td><td> </td><td> </td><td> </td><td> </td><td> </td><td> </td><td> </td> </tr> <tr> <td>15</td><td>5</td><td> </td><td> </td><td> </td><td> </td><td> </td><td> </td><td> </td><td> </td><td> </td> </tr> <tr> <td>45</td><td>5</td><td> </td><td> </td><td> </td><td> </td><td> </td><td> </td><td> </td><td> </td><td> </td> </tr> <tr> <td>90</td><td>5</td><td> </td><td> </td><td> </td><td> </td><td> </td><td> </td><td> </td><td> </td><td> </td> </tr> </table>															TIME SELECTOR CHART		EXIT DELAY TIME (IN SECONDS)			ENTRY DELAY TIME (IN SECONDS)			OUTPUT TIME (IN MINUTES)			TIME	1st BOX	2nd BOX	1st BOX	2nd BOX	1st BOX	2nd BOX	1st BOX	2nd BOX	1st BOX	2nd BOX	5	5	NONE									15	5										45	5										90	5									
TIME SELECTOR CHART		EXIT DELAY TIME (IN SECONDS)			ENTRY DELAY TIME (IN SECONDS)			OUTPUT TIME (IN MINUTES)																																																																								
TIME	1st BOX	2nd BOX	1st BOX	2nd BOX	1st BOX	2nd BOX	1st BOX	2nd BOX	1st BOX	2nd BOX																																																																						
5	5	NONE																																																																														
15	5																																																																															
45	5																																																																															
90	5																																																																															
<table border="1" style="width: 100%; border-collapse: collapse; text-align: center;"> <tr> <td colspan="10">BURGLAR OUTPUT TIME (IN MINUTES)</td> <td>233</td> <td>234</td> </tr> <tr> <td colspan="10">OUTPUT 1 TIME (IN MINUTES)</td> <td>235</td> <td>236</td> </tr> <tr> <td colspan="10">OUTPUT 2 TIME (IN MINUTES)</td> <td>237</td> <td>238</td> </tr> </table>															BURGLAR OUTPUT TIME (IN MINUTES)										233	234	OUTPUT 1 TIME (IN MINUTES)										235	236	OUTPUT 2 TIME (IN MINUTES)										237	238																														
BURGLAR OUTPUT TIME (IN MINUTES)										233	234																																																																					
OUTPUT 1 TIME (IN MINUTES)										235	236																																																																					
OUTPUT 2 TIME (IN MINUTES)										237	238																																																																					

Feature Selection Guide with Programming Record Sheet inserted

Fig. 2-1. Programming aids.





## PROGRAMMING RECORD SHEET (For MAGNUM ALERT-900)

### COMMUNICATOR TRANSMISSION INFORMATION

ALARM/TROUBLE CODES	SINGLE DIGIT	GROUP ONE								GROUP TWO							
		ZONE ONE	ZONE TWO	ZONE THREE	ZONE FOUR	ZONE FIVE	ZONE SIX	ZONE SEVEN	ZONE EIGHT	EXIT ENTRY	Aux. 1 (Panic)	Aux. 2 (Amb.)	Supr. ZONE	Supr. TB.	ZONE TBL.	LOW BATT.	
		000	002	004	006	008	010	012	014	016	018	020	022	024	026	028	
	EXTENDED OR TWO DIGIT	001	003	005	007	009	011	013	015	017	019	021	023	025	027	029	

RESTORE CODES	SINGLE DIGIT	046	050	052	054	056	058	060	062	064	066	068	070	072	074	076
		049	051	053	055	057	059	061	063	065	067	069	071	073	075	077

OPENING/CLOSING CODES	SINGLE DIGIT	CLOSING								CONDITIONAL CLOSING	OPENING							
		USER 1	USER 2	USER 3	USER 4	USER 5	USER 6	USER 7	USER 8		USER 1	USER 2	USER 3	USER 4	USER 5	USER 6	USER 7	USER 8
		030	032	034	036	038	040	042	044		046	076	080	082	084	086	088	090
	EXTENDED OR TWO DIGIT	031	033	035	037	039	041	043	045	SEE NOTE (2) 047	079	081	083	085	087	089	091	093

TELE. #	ALARM/RESTORAL IDENTIFICATION	SUBSCRIBER I.D.	OPENING/CLOSING IDENTIFICATION (3)	FORMAT		PRE-DIAL DELAY	ACCESS #	DIAL TONE DETECTION	TELEPHONE NUMBER							
				RECEIVER	DATA				117	118	119	120	121	122	123	124
①	GROUP ONE		108 109 110 111	112 113					117 118 119 120 121 122 123 124							
	GROUP TWO (4)								125 126 127 128 129 130 131							
②	GROUP ONE		140 141 142 143	144 145					149 150 151 152 153 154 155 156							
	GROUP TWO (4)								157 158 159 160 161 162 163							

#### KEYPAD CODES (DO NOT ENTER ZEROS)

AMBUSH	241 242
PROGRAM <small>(MUST BE PROGRAMMED)</small>	243 244 245 246 247 248
FALLBACK	249 250 251 252

ENTRY	RECEIVER FORMAT
BLANK	ADENCO, SILENT KNIGHT, SLOW
1	SESCOA VERTEX DCI & FRANKLIN (1)
2	RADIONICS, FAST (1)
3	SILENT KNIGHT, FAST
4	RADIONICS DCI FRANKLIN, SLOW (1)
5	(RESERVED)
6	(RESERVED)
7	RADIONICS BFSK (1)
8	ADD FOR 2300 HZ HANDSHAKE

ENTRY	DATA FORMAT
BLANK	EXTENDED OF SINGLE DIGIT
1	SINGLE DIGIT
2	TWO DIGIT OF (4/2)
4	SUM CHECK

- (1) THESE FORMATS TYPICALLY USE A 2300HZ HANDSHAKE ADD AN 8 TO THIS ENTRY
- (2) TWO DIGIT FORMAT ONLY
- (3) MUST BE ENTERED IF "OPENING/CLOSING" CODES PROGRAMMED.
- (4) MUST BE ENTERED, EVEN IF SAME AS "GROUP ONE"

## GLOSSARY

### ABORT DELAY BEFORE DIAL (Locations 213-215)

The communicator can be programmed to wait 16 seconds before reporting a zone violation. Reports for any and all of the following can have an abort-delay period: Burglary Zones 1 through 9 and Fire (Supervisory) Zone alarm. Select each zone for which a transmission delay is desired in locations 213-215.

**NOTE:** If the alarm condition is not removed from Zones 1-8 selected for 24-Hour Protection or Zone Restoral, or from the Fire Zone, before the abort-delay time ends, the communicator will report. To cancel a report, clear the device/zone and then disarm the control center before the delay time elapses. (Hold down Key 9 to reset the detectors and zone after an alarm on the Fire (Supervisory) Zone. See KEYPAD OPERATION.

### AC-FAIL REPORTING (Locations 014-015, 062-063, 179, 183, 208, Lugs E7, E8)

The communicator can be programmed to report an ac power failure. Additional wiring is required.

Ac failure is reported on Zone 8, which cannot then be used for burglary. To report ac failure: (1) Add an 8 to location 179. (2) Enter an alarm/trouble code in location 014 (and 015 for Two-Digit or Extended Receiver Formats). (3) Select Zone 8 for 24-Hour Protection. Add an 8 to location 208. (4) Advise installer to connect Zone 8 for Ac-Failure Detection as described in Chapter 4 (INSTALLATION: Burglary Zones). (5) Optionally program ac power restoral reporting: (a) Add an 8 to location 183. (b) Enter a restoral code in locations 062 (and 063).

The control center must be powered by the standby battery for the communicator to transmit in the event of ac power loss. Advise the user to test the battery weekly by holding down Key 1 until the burglary alarm is heard.

See Data Format.

### ACCESS NUMBER FOR OUTSIDE LINE (Locations 115, 147)

Some telephone subscribers have a telephone system that requires one digit to be dialed to obtain an outside line before the telephone number can be dialed.

The dial tone received before the access number is dialed may have a different frequency from the dial tone received after the access number is acknowledged. One or more 4-second Dial Delay "d"s can be entered before the access number instead of a dial tone with frequency "E". (See Dial Delay.)

If your customer's system uses an access number:

- (1) Ask the telephone equipment supplier whether a different dial tone frequency (not 440 Hertz) is received before the access number is dialed. If the communicator must delay before dialing the access number instead of attempting to recognize the dial tone, ask how many 4-second delays to program.
- (2) For telephone number 1:
  - (a) Enter the dial-tone detection "E" (8 plus 6) or the dial delay "d" (8 plus 5) in location 114. (Enter any extra "d"s that may be needed beginning in location 115.)
  - (b) Enter the access number digit in the first available location beginning in location 115.
  - (c) In the next available locations after the access number, enter any dial delay "d"s needed before the second dial tone, the detection "E" for the second dial-tone frequency, then the telephone number.
- (3) If telephone number 2 is used: repeat step (2) above beginning in location 146. (See Back-Up Reporting, location 186; Double Reporting, location 186.)

Also see "b-F And 10-15".

### ALARM/TROUBLE CODES (Locations 000 029)

See Closing Report and Conditional Closing Report, Report On Alarm/Trouble.

### ALARM OUTPUTS (Locations 216-224, Terminals 34-36, 39-40, 42-43, Jumper E)

The MAGNUM ALERT-900 has an integrated siren driver for both burglary and fire alarms, two relay contact outputs for additional devices and a communicator which can report alarms to a central station. (A bell can be used on the siren output terminals. See "Siren (or Bell) Output" following Table 2-2.)

If different persons program and wire an installation, they should plan the alarm outputs together, since programming selections and wiring must match for an alarm to signal. Table 2-2 summarizes wiring and programming for signalling an alarm in typical installations. Programming instructions are explained in detail below. Wiring instructions are explained in the INSTALLATION section of this manual.

DEVICE TYPE	WIRING INSTRUCTIONS	SELECT ALARM OUTPUT IN LOCATIONS	ENTER TIME OUT IN LOCATIONS	SPECIAL FEATURES	
				NAME	TO PROGRAM:
Burglary Siren	Speaker on 42-43.	216-218	233-234		
Fire Siren	Speaker on 42-43.	---	239-240		
Burglary Bell	Bell on 42-43, cut Jumper E.	216-218	233-234		
Supervisory Zone Bell	Bell on 42-43, cut Jumper E.	---	239-240	Pulsing Supervisory Alarm	Add 1 to location 189.
Latching Fire Detectors	Use Terminals 36-37.	---	---	Reset Output 2 Devices	Add 2 to location 189.
Relay for House Lights	Use Terminals 39-40.	219-221	235-236		
Accessories powered from external supply	Use Terminals 39-40; cut Jumper A at Terminal 40 to isolate contacts.	219-221	235-236		

Table 2-2. Alarm output wiring and programming for typical installations.

#### Siren (or Bell) Output

The integrated siren driver is connected to Terminals 42-43. Normally, a siren speaker is connected to these terminals. If connecting a bell instead of the speaker, cut Jumper E.

Burglary output for the device on Terminals 42-43 is selected in locations 216-218.

Generally, the Fire (Supervisory) Zone is reserved for fire alarm and trouble detection. The Fire (Supervisory) Zone will automatically activate the fire signal.

The siren driver will signal burglary alarms with a sweep and produce a steady fire-alarm signal. Any fire (supervisory) alarm will override a burglary alarm. It is possible to pulse the supervisory siren on alarm by programming a 1 in location 189. When using a bell on Terminals 42-43, it is necessary to program pulsing supervisory alarm in order to distinguish between fire (supervisory) and burglary alarms.

#### Output Relay Contacts

There are two sets of output relay contacts: Output 1 (Terminals 39-40) and Output 2 (Terminals 34-36). Either set of contacts can provide 12 volts output or, alternatively, be isolated by cutting a jumper for a device with its own power supply.

A zone that has been selected for burglary alarm output (locations 216-

218) can also be selected to use either or both relay outputs.

Activate alarm output devices attached to relay Output 1 by selecting the activating detection zones in locations 219-221.

Activate alarm output devices attached to relay Output 2 by selecting the activating zones in locations 222-224. *Exception:* Powered fire detectors must be reset by holding down Key 9. (See **KEYPAD OPERATION.**) If powered fire detectors are not the self-resetting type: (a) Select Reset Output 2 Devices by adding a 2 to location 189. (b) The detectors must be connected to Output 2. (See **INSTALLATION** section: Terminals 11-12.) When Reset Output 2 Devices is selected, holding down Key 9 causes power the detectors to be momentarily interrupted. If a 2 is programmed in location 189 (Reset Output 2 Devices), Output 2 will not activate an alarm for any zone in locations 222-224 or 237-238.

See Alarm Time Out.

#### **ALARM TIME OUT (Locations 233-240)**

If Alarm Time Out is not programmed for an alarm output, an alarm output device activated by that output will signal until the control center is disarmed. If a time-out period is programmed for an alarm output, the signal activated by that alarm output will automatically stop at the end of the time period.

If both burglary and fire (supervisory) alarms occur together, the burglary alarm will be silent until the fire (supervisory) alarm finishes signalling. The burglary alarm will then signal for the remainder (if any) of its time-out period, or continuously if no time-out period is programmed.

Each alarm output can be programmed for a different time-out period. Use the locations shown in Table 2-3.

ALARM OUTPUT	TERMINALS	PROGRAM TIME-OUT PERIOD IN:	
		1st LOCATION	2nd LOCATION
Burglary Output	42-43	233	234
Output 1 (1)	39-40	235	236
Output 2 (2)	34-36	237	238
Fire (Supervisory) Output (3)	42-43	239	240

**NOTES:**  
(1) If Output 1 is used to activate an electric door switch, a time out period is not used.  
(2) If Output 2 is used to reset latched fire detectors, a time out period is not used.  
(3) Fire (Supervisory) Zone preprogrammed for fire output. In the State of California, do not program Alarm Time Out for fire alarms.

Table 2-3. Enter alarm time-out period in the above PROM locations.

Each alarm time out period programmed is in minutes. The minimum alarm time for U.L. residential installations is 4 minutes. To enter a time-out period, see instructions for Time Selection.

See "b-F And 10-15". Also see "Auto-Reset".

#### **AMBUSH CODE (Locations 020-021, 068-069, 180, 184, 241-242, Terminals 28-29)**

Auxiliary Zone 2 is prewired to report an ambush (holdup) alarm to the central station. Alternatively, Terminals 28-29 can be used for an additional 24-Hour Zone.

The keypad can be used to trigger an ambush (holdup) alert if the user is approached by an intruder while reentering his premises. Entering the ambush code before the disarm codes silently alerts the central station of the intruder, while the user appears to be merely disarming the system.

It is not recommended to select Auxiliary Zone 2 for audible alarm output or restoral reporting when it is used for ambush.

To allow an ambush alarm report:

(1) Enter 2 digits for the ambush code in locations 241-242.

- (2) Select Auxiliary Zone 2 to report on alarm (4 in location 180).
- (3) Enter an alarm report code for ambush on Auxiliary Zone 2 (locations 020-021)
- (4) Advise the installer that Auxiliary Zone 2 will be used for holdup and that an alarm condition on that zone will report to the central station as a holdup.
- (5) Inform the end-user (a) what digits are programmed as the ambush code and (b) that the keypad arm/disarm code must be entered within 8 seconds after the ambush code for an ambush report to be transmitted.

Do not program Auxiliary Zone 2 for restoral report when used for ambush alarm, since the zone will auto-reset and report restoral immediately following the alarm.

See also Panic Alarm.

#### ANTI-JAM TIME (Location 006 - PROM Page 1)

If the communicator does not detect a dial tone within 12 seconds, Anti-Jam will be activated. The communicator will go off line for 16-seconds to free the telephone circuit from incoming calls, then make another 12-second attempt at dial-tone detection. If still unsuccessful, the communicator will again go off line for 16 seconds, then proceed to dial anyway.

Consult the telephone-equipment supplier to determine if a longer time is required for Anti-Jam to function. To increase the interval from the factory-set 16 seconds to 31 seconds, set the PAGE switch on the PRO-410 to [1], erase memory and enter an "F" in location 006 (see CAUTION after PROGRAMMING STEP 3.

To test, access the alarm phone line from a different line, then activate an alarm. The incoming call should be disconnected by the control center.

#### ARMING WITHOUT AC

If the ac power source fails during the time the controller is disarmed, the red ARMED/ALARM, green STATUS and yellow SHUNT LEDs on the keypad will blink together.

To arm with the control center powered from the standby battery, instruct the user to: (1) Hold down Key 1 until the alarm sounds to test the standby battery. (2) Hold down Key 9 until the Mini-Sounder beeps, then enter the arming code within 2 minutes.

There is no keypad indication if ac power fails while the control center is armed.

See Ac-Fail Reporting, Low-Battery Reporting, KEYPAD OPERATION chapter.

#### AUDIBLE TEST ON ARMING (Location 188)

To test the burglary alarm each time the control center is armed, add a 1 to location 188. The burglary alarm will then signal briefly at the time the control center is armed. If the alarm does not sound properly, either the alarm device or the battery may be defective.

#### AUTO-RESET (Locations 188, 209-210)

Normally, if a zone selected for Auto-Reset trips an alarm, it will automatically rearm itself as soon as it is cleared of the alarm condition.

Alternatively, if the zone activates an alarm output with a programmed time-out period, auto-reset can occur after the time-out period. To delay Auto-Reset until an alarm times out, add a 2 to location 188.

To prevent "swingers" from causing repeated false alarms, Zones 1 through 8 with Auto-Reset will only reset twice (3 alarms), until rearmed.

Zones not programmed for Auto-Reset will be incapable of sounding another alarm until (a) the cause of the alarm has been removed from the zone (see note below), and (b) the zone is manually reset by disarming.

**NOTE:** Key 9 is required to reset a fire alarm (see KEYPAD OPERATION).

Auto-Reset may be selected for Burglary Zones 1-8. Exit/Entry Zone 9, Auxiliary Zones 1 and 2, and the Fire (Supervisory) Zone are preselected for Auto-Reset without programming.

See Alarm Outputs, Alarm Time Out. See also Restoral Report.

**AUTO-SHUNT** (Locations 201-202)

See Remove Auto-Shunt.

**b-F AND 10-15**

The display on the programmer shows entries as they are programmed, but displays "0" for the number 10 and letters "b", "C", "d", "E" and "F" for the numbers 11 through 15, respectively.

DISPLAY	ENTRY TOTAL	FIRST ENTRY	SECOND ENTRY
0	10	0	-
b	11	8	3
C	12	8	4
d	13	8	5
E	14	8	6
F	15	8	7

Table 2-4. Programming entries larger than 9.

**PRO-410 Programmer**

When programming with the PRO-410 Programmer you may use [0], [b]-[F] keys for the numbers 10 to 15. Alternatively, program [b] through [F] (11 through 15), using Table 2-4 above, this way: Enter the number [8], press [PLUS], then enter the second number in the same location. Refer to the instructions for this programmer.

**BACK-UP REPORTING** (Locations 186, 132-163)

When this method of reporting has been selected, and the communicator makes two unsuccessful attempts to reach telephone number one, it will make seven attempts to reach telephone number two.

To select Back-Up Reporting:

- (1) Add a 4 to location 186.
- (2) Follow the instructions for Subscriber Identification Number, Receiver Format, Data Format, and Telephone Number to program the information needed for the first telephone in locations 100-131, and for the second telephone in locations 132-163. See Double Reporting; Touch-Tone Dialing.

**CLOSING REPORT AND CONDITIONAL CLOSING REPORT** (Locations 030-047, 108-111, 140-143, 181, 187)

On arming, the communicator can transmit to the central station, a closing code for each user, a conditional closing code, and a status report that identifies a problem zone.

Select (unconditional) closing for a report be sent every time the control center is armed. Each user may have a different closing code. See Table 2-5.

Select conditional closing for a report to be sent only when arming with a problem zone(s): auto-shunted zone, zones latched in alarm, or a low-battery condition. This transmission will consist of a closing code, followed by the conditional closing code.

Select closing report, together with conditional closing report for a closing code to be sent every time when arming; followed by a conditional closing if there is a problem zone.

Select conditional closing status report for a conditional closing report to be sent followed by a status report which identifies the problem zone(s). The second locations of the alarm/trouble codes are used for this identification. If that location is empty (Single-Digit Data Format) the first location will be used. (See example following Table 2-5.)

To select closing report: (1) Add an 8 to location 181. (2) Enter a closing subscriber identification number for each telephone used (Table 2-10).

(3) Enter a closing code for each user (Table 2-5). (4) Enter a conditional closing code (locations 046-047).

To select conditional closing report: (1) Add a 2 to location 187. (2) Enter an opening/closing subscriber identification number for each telephone number used (Table 2-10). (3) Enter a closing code for each user (Table 2-5.) (4) Enter a conditional closing code (locations 046-047).

To select conditional closing status report: (1) Add a 4 to location 187. (2) Enter a closing subscriber identification number for each telephone number used (Table 2-10). (3) Enter a closing code for each user (Table 2-5). (4) Enter a conditional closing code (locations 046-047). (5) Enter an alarm/trouble code (locations 000-029) for each zone/condition for which status reporting is desired.

CLOSING CODE LOCATIONS		
USER	1st DIGIT	2nd DIGIT*
First	030	031
Second	032	033
Third	034	035
Fourth	036	037
Fifth	038	039
Sixth	040	041
Seventh	042	043
Eighth	044	045

\*Use the 2nd digit for Extended or Two-Digit Data Format. (See Data Format.)

Table 2-5. In locations shown, enter closing code for each assigned user.

Example (Conditional Closing Status Report): A burglar breaks through a mercantile establishment window during the night. The window foil is broken. Alarm subscriber number is 123, alarm code is 1 (Burglary Zone 1); opening/closing subscriber number is 456, conditional closing code is F; closing code is C for user one. The communicator will send the following to the central station (Single-Digit Data Format):

- 1231 - Sent at the time the alarm occurs.
- 456C - Closing: The user has returned, inspected the damage, and rearmed.
- 456F - Conditional closing.
- FFF1 - Zone status at time of closing: Window foil still broken. Zone 1 auto-shunts. Repair service is required for this zone.

**NOTE:** Unlike an alarm report, a status report uses the same code for group one or group two zones. This may cause two zones to have identical status reports (unless two account numbers are used).

See Data Format; Start Exit Delay After Closing Ringback; Subscriber Identification Number. Also see Opening Report.

#### COMMUNICATOR CONFIDENCE TEST (Location 189)

When this feature is selected, the subscriber can verify before arming that the communicator is able to dial out. Key 6 is depressed until the Mini-Sounder pulses rapidly while the communicator attempts to detect a dial tone. If successful, the sounder will go off, indicating that telephone lines and communicator are operating properly. The Mini-Sounder will sound steadily if the communicator cannot dial out, and may be silenced by holding down Key 9.

The user should attempt to dial out over a voice line to determine whether service is required for the telephone line or the communicator.

When closing report is selected (8 in location 181), and no ringback is received on arming, the user can test the telephone line to determine if the problem is occurring at the installation or the central station. If the test indicates that the communicator dials out successfully, the central station receiver may not be operating.

To enable the telephone line Communicator-Confidence test hold-down function (Key 6), add a 4 to location 189.

See KEYPAD OPERATION for detailed user instructions.

#### CONTROL-CENTER RESTORAL REPORT (Locations 182-185)

See Restoral Report.

#### DATA FORMAT (Locations 113, 145)

The central station will advise which of the following formats to use for event codes:

##### Extended Format

Extended format reporting allows the communicator to transmit an extra digit to the central station. The extra digit is generally used to report the zone on which the alarm occurred and the alarm code identifies the type of alarm. For example, an installation might use the following programmed transmission information:

Subscriber identification number 678,  
Report on alarm/trouble selected for zone 3,  
Extended format alarm code 13 (burglary alarm type 1, Zone 3).

If an alarm occurs on Zone 3, the communicator will transmit:

6781 (indicating subscriber 678 reported a burglary alarm)  
6781 (repeat of above)  
1113 (indicating the burglary alarm reported was on Zone 3)  
1113 (repeat of above)

Extended format may be used with most standard central-station receivers. Any receiver capable of recognizing multiple reporting will also recognize extended format. The central station will advise the event codes to be programmed.

To use extended format reporting:

- (1) Extended format does not require any programming in locations 113, or 145.
- (2) Follow steps (2) through (5) for Two-Digit Event Code Format, which follows later in this Data Format section.

##### Single-Digit Event Code Format

If the receiver cannot accept multiple reporting:

- (1) Add a 1 in location 113, (145 for second telephone number if used - see Double Reporting and Back-Up Reporting).
- (2) Enter the first digit for any alarm codes, restore codes, and opening/closing codes. (See Report On Alarm/Trouble; Restoral Report; Closing Report and Conditional Closing Report; Opening Report; Opening Report After Alarm.)

**NOTE:** If it is desired to have a single digit event code for one telephone number and extended format for the other program both digits for all event codes. (Use programming steps (2) through (5) for Two-Digit Event Code, which follows.) The telephone number with a 1 in location 113, or 145, will transmit only the first digit. The other telephone number will use both digits. (Single-Digit Format will override Two-Digit Format location 113 or 145.)



### Two-Digit Event Code Format

Some central-station receivers require a two-digit code to be sent in each report. For example, if alarm subscriber number is 123 and a burglary alarm occurs on Zone 1 (alarm code 31), the communicator will send 12331.

To use two-digit event code format:

- (1) Add a 2 in location 113, (145 for second telephone number, if used). See Double Reporting and Back-Up Reporting.
- (2) Enter an alarm/trouble code (locations 000-029) as explained in steps (a) and (b) for each zone or condition to report on alarm/trouble (locations 178-181 - see Report On Alarm/Trouble) or conditional closing status report (location 187, - see Closing Report And Conditional Closing Report):
  - (a) Enter the first digit of the alarm/trouble code. (You may use this digit to indicate alarm type.)
  - (b) Enter the second digit of the alarm/trouble code. (You may use this digit to indicate zone.)
- (3) Repeat step (2) to enter restore codes (locations 048-077) for each zone selected for control center restoral report (locations 182-185) or zone restoral report (locations 192-193). (See Restoral Report.)
- (4) If opening report (8 in location 185) or opening report on alarm (1 in location 187) is selected, enter a two-digit opening code (locations 078-093) for each user. (See Opening Report, Opening Report On Alarm.)
- (5) If closing report is selected (8 in location 181), enter two-digit closing codes (locations 030-045) for each user. If conditional closing or conditional closing status report is selected (location 187), enter a two-digit conditional closing code (locations 046-047). (See Closing Report and Conditional Closing Report.)

Selecting Single-Digit Format will override Two-Digit Format location 113 or 145.

### Sum-Check Format

Sum Check is a sophisticated data transmission format used to enhance both the speed and accuracy with which the transmission is received. Select this feature when the central station receiver is capable of receiving this format.

Sum check works in the following way: After transmitting both the subscriber identification number and event code, the communicator sends a verifying digit, which is the sum of the subscriber identification number and event codes. The receiver compares this digit to the sum of the digits it receives to verify the accuracy of the transmission.

To use sum check format, add a 4 in location 113 (145 for second telephone number, if used - see Double Reporting and Back-Up Reporting).

### DAY ZONE (Locations 194-195)

A Burglary Zone programmed for Day Zone (locations 194-195) will cause visual and audible indication at the keypad if the zone's loop has an abnormal open condition. This feature can be used to warn of trouble during the day, when the control center is not armed. If a Day Zone experiences abnormal trouble (a break in the window foil, for example), the green keypad STATUS LED will flash rapidly, the zone number will be identified on the keypad display, and the Mini-Sounder at the keypad will pulse. Hold down Key 9 to turn off indicators. The green STATUS LED will blink every second until all trouble is repaired.

The same zone cannot indicate a Day-Zone trouble a second time until the system is armed and disarmed.

Any Burglary Zone 1 through 8 may be selected for one or both of the Day Zone supervision conditions.

To disable the Mini-Sounder Day Zone trouble indication, add an 8 to location 188.

A communicator report can also occur if a 2 is programmed into location 181. (See Closing Report and Conditional Closing Report, Report On Alarm/Trouble.)

Also see KEYPAD OPERATION.

#### DIAL DELAY (Locations 114, 146)

Dial Delay may be used whenever a delay is needed before dialing.

Usually, it is also required to program dial tone detection, which causes the communicator to wait to detect a dial tone before dialing. (See Dial Tone Detection.) Certain telephone exchanges send a nonstandard dial tone which the communicator may not be able to detect. With these nonstandard exchanges it is possible to program dial delay, and not program dial-tone detection, which forces the communicator to wait a predetermined period of time before dialing.

Call the telephone equipment supplier to determine how long a delay may be needed before dialing. Select dial delay by inserting one "d" ([8] [plus] [5]) for each 4-second delay needed. Begin entering dial delay "d"s in location 114 for telephone number 1. (See Double Reporting, Back-Up Reporting - location 186 - to determine if telephone number 2 is needed. Begin entering dial delays for telephone number 2 in location 146, if used). Dial delays may be needed before each dial tone in installations requiring an access number. (See Access Number For Outside Line.) Also see "b-F And 10-15"; Telephone Number.

#### DIAL-TONE DETECTION (Locations 116, 148)

At least one dial-tone detection entry is usually required in each telephone number used to ensure that a dial tone is present before the communicator dials.

The communicator dial-tone detection circuit is set to detect the standard frequency of 440Hz when an "E" ([9] [plus] [6]) is programmed before the first digit of an outside telephone number. (The "E" is generally entered in location 116 for the first telephone number, and location 148 for the second telephone number, if used.)

It may be necessary to program at least one 4-second dial delay before a dial-tone detection "E". With certain nonstandard exchanges, dial-delay "d"s may be used without a dial-tone detection "E". (See Access Number For An Outside Line; Dial Delay.)

#### DOUBLE REPORTING (Locations 186, 132-163)

Double Reporting transmits through telephone number two a duplicate of all the information sent through telephone number one. To use double reporting:

- (1) Add an 8 to location 186.
- (2) Follow the instructions for Subscriber Identification Number, Receiver Format, Data Format, and Telephone Number to program the information needed for the first and second telephone numbers.

#### EXIT/ENTRY DELAY

Zone 9 is the Exit/Entry delay Zone. The exit delay allows the user time to exit the premises without causing an alarm after the control center has been armed. The entry delay allows the user time to enter the premises and

disarm the control center without causing an alarm. Upon entering, the keypad Mini-Sounder sounds steadily to remind the user to disarm the control center. Exit/entry delay can be cancelled by holding down Key 4.

Exit and entry delay times may be selected up to 255 seconds (4-1/4 minutes) by programming (locations 229-232). See Time Selection. For U.L. installations, the maximum exit delay is 60 seconds and the maximum entry time is 45 seconds. If delay times are not programmed, exit delay time will be 60 seconds and entry delay time will be 30 seconds.

**NOTE:** If Auto-Shunt is not removed from Zone 1 (location 201), it will also be programmed for Exit/Entry Zone 9, and the door must be closed before arming or Zone 9 will be shunted.

See Exit/Entry Follower, Start Exit Delay After Closing Ringback. Also see KEYPAD OPERATION.

#### EXIT/ENTRY FOLLOWER (Locations 211-212)

Burglary Zones 1 through 8 may be programmed to delay detection during the exit and entry delay periods. Detection devices (for example, passive infrared detectors) along the exit/entry path between the keypad and the door will then not signal an alarm during these delay periods. When armed, entry on Exit/Entry Zone 9 will prevent detection on Exit/Entry Follower Zones until the entry delay period is over.

If the control center is armed with the exit/entry delays cancelled, any violation on Exit/Entry Zone 9 or an Exit/Entry Follower Zone will cause an immediate alarm.

**NOTE:** If Start Exit Delay After Closing Ringback is selected (location 188), Exit/Entry Follower Zones will not arm until either a ringback signal is received, or Start Exit Delay Without Ringback (Hold-Down Function 5) is used.

#### EXTENDED FORMAT REPORTING (Locations 000-093, 113, 145)

See Data Format.

#### FALLBACK CODE (Locations 249-252)

A fallback code can be used to arm/disarm if no keypad-programmed user codes are loaded. (User codes are erased when the control center is disabled by a power loss, or the START switch on the control-center circuit board is pressed.) The 4-digit fallback code is programmed in locations 249-252. This feature is frequently provided to allow the control center to be disarmed following a power loss, if it is wired to restore in an armed condition. (See Chapter 4, INSTALLATION: Arming Options.)

**CAUTION:** To prevent unauthorized entry using the fallback code, user codes should be reentered through the keypad as soon as possible. (See Keypad Program Code.)

#### FEATURE SELECTION GUIDE

A specially-designed slide card that simplifies programming.

#### GROUP SHUNT (Locations 205-206)

See Manual Shunting.

#### KEYPAD PROGRAM CODE (Locations 243-248)

When entered on the keypad, the 3- to 6-digit Keypad Program Code allows the user to program up to 8 different arm/disarm codes and an access control code through the keypad. Only the alarm system owner or that end-user authorized to alter these codes should be advised of the PROM-programmed keypad program code.

Up to 8 different arm/disarm codes can be programmed from the keypad. The arm/disarm codes are programmed by the authorized user and determine which opening/closing codes (if programmed) will be sent when a particular

arm/disarm code is entered.

The access control code is used by those persons authorized to enter the premises without first being identified by someone inside the premises who must release the access door. When this code is pressed on the keypad, an electric door switch connected to Output 1 Terminals 39-40 is activated, automatically releasing the door. If an access control code is needed at the installation, advise the installer to wire the necessary door switch as explained in INSTALLATION (Chapter 4).

See the KEYPAD OPERATION (Chapter 3, "Hold-Down Function 8") for specific instructions in programming these codes through the keypad and using them as arm/disarm and access codes.

To assign the authorizing keypad program code, enter 3 to 6 digits in locations 243-248 and inform that end-user authorized to program through the keypad what code is contained in the PROM. Do *not* enter zeros or letters.

High-security keypad programming may be obtained by adding an 8 to location 189. This will require opening the control-center door to gain access to the START switch. The authorized user can still program through the keypad by pushing the START switch at the upper-left corner of the control-center circuit board before following the normal keypad programming procedure.

#### LOOP RESPONSE (Locations 225-228)

Loop Response is the length of time that a normally-closed circuit must remain open or a normally-open circuit must be closed in order to trigger an alarm. The slower the response time, the safer the installation is from false alarms resulting from intermittent activation of the loops. In order to minimize false alarms use the longest loop response time that your system allows.

Possible loop response times are:

- (a) 7 milliseconds (7/1000 of a second) is an extremely fast loop response time, used primarily for Window Bugs, and to eliminate the need for a pulse extender.
- (b) 50 milliseconds (50/1000 of a second) is used for momentary panic buttons and area protection devices such as photoelectric eyes, passive infrareds, floor mats, etc.
- (c) 750 milliseconds (750/1000 of a second) is the slowest loop response time, and is recommended for use with magnetic contacts, window foil, etc.

Auxiliary Zones 1 and 2 are preselected (without programming) for a loop response time of 50 milliseconds. Burglary Zones 1 through 9, and the Fire (Supervisory) Zone are preselected (without programming) for 750-millisecond response. The Fire (Supervisory) trouble zone has a preselected 10 second delay, to prevent an alarm during reset. The 750-millisecond response time on Burglary Zones 1 through 8 can be changed to 7 milliseconds (by programming locations 225-226) or to 50 milliseconds (by programming locations 227-228).

**NOTE:** If both 7 millisecond response and 50 millisecond response are selected on the same zone, the zone will respond in 7 milliseconds.

#### LOW-BATTERY REPORTING (Locations 028-029, 076-077, 181, 185)

The system automatically tests the battery under load for 10 seconds every 30 minutes. An alarm or restoral report is sent during this test period. If programmed, the communicator will report a low-battery condition when the control-center standby battery voltage has fallen below 10.2 volts dc.

To obtain low-battery condition reporting:

- (1) Enter a low-battery alarm/trouble code in location 028 (and 029 with two-digit or extended data format).
- (2) To send an alarm report, add a 4 to location 181. (See Report On Alarm/Trouble.)
- (3) To cause a restoral report to be sent after the battery is recharged or replaced, add a 4 to location 185 and enter a low-battery restore code in

location 076 (and 077 with two-digit or extended data format).

No Mini-Sounder or LED indication occurs at the time battery voltage drops below normal. Advise the user to test the battery weekly by holding down Key 1. (See KEYPAD OPERATION.)

#### MANUAL SHUNTING (Locations 203-206)

Manual shunting is the action of making one or more zones inactive. Manual shunting is often used to make interior protection zones inactive, so that a user may move inside the premises, but still be protected from intrusion through armed perimeter protection areas.

The user can individually shunt any number of those Burglary Zones 1 through 9 programmed for selective shunt by pressing Key [S] followed (within 8 seconds) by the zone number. Program Burglary Zones 1 through 8 for selective shunt in locations 203-204. Programming Zone 1 for selective shunt also enables Zone 9 for selective shunt.

By pressing Key [S] *twice*, the user can also shunt a group of any number of these zones included in a program-defined group shunt. Choose those Zones 1 through 8 to be included in the group shunt in locations 203-204 and 205-206. Zone 9 may not be included in the group.

Zones must be shunted while the control center is disarmed. The yellow SHUNT LED will go on after the first shunt request. Hold down Key 2 to identify manually-shunted zones. Shunting of any zone or group is cancelled when the system is disarmed.

See KEYPAD OPERATION, Chapter 3.

#### OPENING REPORT (Locations 078-093, 108-111, 140-143, 185)

Opening and closing reporting are typically used in mercantile installations.

If Opening Report is selected, an opening code is transmitted to the central station in the morning when the control center is disarmed.

To provide opening reporting:

- (1) Add an 8 to location 185.
- (2) Enter a separate opening code in the locations shown in Table 2-7 for each disarm code.
- (3) Enter an opening/closing subscriber identification number for each telephone number used (Table 2-10).

See Data Format. Also see Closing Report and Conditional Closing Report.

Table 2-7. Enter the opening report code in the location(s) shown for each assigned arming code.

\*Use the 2nd digit for Two-Digit or Extended Data Format.

USER	1st DIGIT	2nd DIGIT*
First	078	079
Second	080	081
Third	082	083
Fourth	084	085
Fifth	086	087
Sixth	088	089
Seventh	090	091
Eighth	092	093

OPENING REPORT AFTER ALARM (Locations 078-093, 108-111, 140-143, 187)

If this feature is selected, the communicator will only transmit an opening code when the control center is disarmed after an alarm has occurred on Zones 1 through 9. This feature may be used by the central station to verify that the subscriber has responded to the alarm and has disarmed his system.

To select opening report after alarm:

- (1) Add a "1" to location 187.
- (2) Enter an opening code in the locations shown in Table 2-7 (see Opening Report) for each disarm code.
- (3) Enter an opening/closing subscriber identification number for each telephone number used (Table 2-10).
- (4) Do not select (unconditional) opening report (8 in location 185).  
See Data Format. Also see Closing Report and Conditional Closing Report.

PANIC ALARM (Terminals 27-28)

The keypad and Auxiliary Zone 1 are prewired to signal a panic alarm.

To disable keypad panic input to Auxiliary Zone 1, cut the brown jumper at the lower end of the keypad circuit board, behind the [S] key. Advise the installer that this zone is used for panic alarm, and to show the user how to initiate a panic alarm by pressing the keypad [\*] and [\*] buttons at the same time.

Additional programming is required to obtain an audible panic alarm and/or silent communicator panic reporting. (See Alarm Outputs, Closing Report and Conditional Closing Report, Report On Alarm/Trouble.) Do not program Auxiliary Zone 1 for restoral report when used for panic alarm, since the zone will auto-reset and report a restoral immediately following the alarm.

Also see Ambush Code.

To install a remote panic switch, splice the black and pink ribbon wires to a normally-open momentary-contact pushbutton. Additional panic buttons may be similarly wired in parallel with the first, as needed. If the remote-panic feature will not be used, insulate both black and pink leads carefully, as a short between them will cause a panic alarm.

**NOTE:** In U. L. installations, remote panic buttons must be located in the same room as the keypad.

PRIORITY (Locations 198-200)

When a zone selected for priority is in trouble, the control center will not arm, the Mini-Sounder will sound continuously, and a zero will appear on the keypad digital display. Enter the arm/disarm code a second time to silence the sounder.

Priority can be individually selected for Burglary Zones 1 through 9, Auxiliary Zones 1 and 2, and the Fire (Supervisory) Zone.

If Priority is selected and Auto-Shunt has not been removed (locations 201-202), priority will override the shunt. A zone in trouble that is neither a Priority Zone nor an Auto-Shunt Zone will cause an alarm on arming.

**PRIORITY WITH BYPASS** (Locations 196-197)

Normally, if a trouble exists on a zone selected for Priority (locations 198-200), the panel will not arm, the Mini-Sounder will sound continuously and a "0" will be displayed at the keypad. If the Priority Zone is also a Selective-Shunt Zone (locations 203, 204), the zone may be shunted out manually.

By selecting Priority With Bypass (locations 196, 197), the priority condition may be bypassed by first entering the Arm/Disarm Code, then holding down Key 9 before arming. This will cause the zone to be auto-shunted and to report a conditional closing, if selected. Priority with Bypass may be programmed for any Zone 1 through 8 that has not been selected for Priority

**NOTE:** When programming Priority With Bypass, do not select Remove Auto Shunt.

**PROGRAMMING RECORD SHEET**

The entries to be programmed on a subscriber PROM are first written on a Programming Record Sheet. The completed sheet aids in programming and can later be filed as a permanent record for the installation.

An MA-900 Programming Record Sheet has been reproduced earlier in this section for reference purposes.

**PULSING SUPERVISORY ALARM** (Location 189, Terminals 42-43)

See Alarm Outputs.

**RECEIVER FORMAT** (Locations 112, 144)

The communicator can be programmed to transmit to any standard receiver used by a central station. One receiver format must be entered for each telephone number used, and a different receiver format can be assigned to each.

See Double Reporting and Back-Up Reporting to determine whether telephone number 2 will be programmed. Call the central station at each telephone number needed for receiver description. Select the receiver format entry for each telephone number from Table 2-8.

ENTRY	RECEIVER FORMAT	DATA TRANSMIT (Hz)	DUTY CYCLE ON/OFF (mSec)	INTERDIGIT TIME (mSec)
blank	Ademco, Silent Knight "slow"	1900	51/49	600
1	Sescoa, Vertex, DCI, and Franklin	1800	30/20	800
2	Radionics "fast"	1800	13/12	400
3	Silent Knight "fast"	1900	40/30	560
4	Radionics, DCI, and Franklin "slow"	1800	51/49	600
5	Reserved			
6	Reserved			
7	Radionics BPSK			
8	Add 8 for 2300Hz handshake. Do not add if 1400Hz handshake.			

Table 2-8. Enter the number in the left column to select the corresponding receiver format described on the right.

Enter the receiver format in location 112 for telephone number 1. Enter the receiver format for telephone number 2 in location 144 if used. (See Double Reporting, Back-Up Reporting.)

**REMOTE PANIC** See PANIC ALARM

**REMOVE AUTO-SHUNT** (Locations 201-202)

If trouble exists only on shuntable zones, the control center can still be armed. Burglary Zones 1-9 are preprogrammed for Auto-Shunt, and will be

bypassed (shunted out) when in trouble. A 2-second warning will sound at the keypad to indicate that the control center has been armed without the protection of the shunted trouble zones.

**NOTE:** The exit/entry door must be closed before arming, or Zone 9 will be shunted.

The Auto-Shunt feature can be removed from Zones 1-8 by programming. If Auto-Shunt is removed from Zone 1, it is also removed from Zone 9.

**NOTE:** If Auto-Shunt is removed from a trouble zone that is not programmed for priority arming (locations 198-200), that zone will cause an alarm on arming. Also, when programming Priority With Bypass, *do not* select Remove Auto-Shunt.

For U.L. installations, non-24-Hour Zones *with* auto-shunt (Remove Auto-Shunt *not* programmed) must be programmed for Priority Zone with Bypass. If an attempt is made to arm with these zones in trouble, the Mini-Sounder will come on, "0" will be displayed, and the panel will not arm (enter the arm/disarm code to silence the sounder and clear the display). To arm, hold down Reset Key [9] for about 2 seconds, then enter the arm/disarm code.

#### REPORT ON ALARM/TROUBLE (Locations 000-029, 178-181)

The following conditions may be programmed to result in a central station report: an alarm on Burglary Zones 1 through 9, Auxiliary Zones 1 or 2, or the Fire (Supervisory) Zone; trouble on the Fire (Supervisory) Zone or a Day Zone; low battery. Ac power loss reporting may replace an alarm report on Zone 8 (see Ac Fail Reporting).

Zones not selected to report an alarm are limited to activating the alarm outputs. If no trouble report is selected for the Fire (Supervisory) or Day Supervision Zones, trouble warning is limited to the indication at the keypad. Ac-failure indication occurs only when the system is disarmed. If low battery is not reported, this condition can only be detected by holding down keypad Key 1. (See KEYPAD OPERATION, Chapter 3.)

Select alarm reporting in locations 178-180 and trouble reporting in location 181, then enter an alarm/trouble report code for the corresponding alarm zone or trouble condition in locations 000-029. Enter the second digit for each alarm/trouble code only if using Two-Digit Format (locations 113, 145) or extended format reporting. (See Data Format.)

See Day Zone, Closing Report and Conditional Closing Report.

#### RESET OUTPUT 2 DEVICES (Location 189, Terminals 34-36)

There are two ways powered fire (smoke) detectors can be reset after they are cleared of smoke:

- (1) Some fire detector models automatically reset themselves.
- (2) If fire detectors are not self-resetting, Reset Output 2 Devices must be programmed, and the detectors wired to the Output 2 contacts. Pressing Key 9 will then momentarily remove power from fire detectors and reset them when they are cleared of the smoke. (See KEYPAD OPERATION.)

If the installation's fire detectors are not self-resetting:

- (1) Program Reset Output-2 Devices by adding a 2 to location 189.
- (2) The auxiliary contacts on Output 2 may not be used for activating an alarm device.
- (3) Advise the installer to wire detectors to Output 2. (Wiring instructions are in the INSTALLATION section: Terminals 11-12.)

#### RESTORE CODES (Locations 048-077)

See Restoral Report.

#### RESTORAL REPORT (Locations 048-077 182-185, 192-193)

The communicator will transmit a report to the central station when the control center or a zone is restored following any of these conditions: an alarm on Burglary Zones 1 through 9, Auxiliary Zones 1 or 2, or the Fire (Supervisory) Zone; trouble on the Fire (Supervisory) Zone; low battery. Ac



power restoration may replace restoral reporting for Zone 8 (see Ac Fail Reporting).

To cause a report to occur at a time shown in Table 2-9 and the notes that follow it, program the zone features shown in the table, and a restore code for every restoral reporting zone.

TIME REPORT SENT			
		CONTROL CENTER RESTORAL REPORT (Locations 182-185) (1)	ZONE RESTORAL REPORT (Locations 192-193 and 182-185) (1), (2), (3)
INSTANT AUTO-RESET (Locations 209-210) (3)	As soon as one of the following occurs: A) Zone is repaired. B) Control Center is disarmed.	As soon as zone is repaired, regardless of whether control center is armed or disarmed.	
AUTO-RESET AFTER ALARM TIMEOUT (Locations 209-210; 2 in 188)	As soon as one of the following occurs: A) Zone resets (alarm times out and zone is repaired). B) Control center is disarmed.	When zone resets (alarm times out and zone is repaired), regardless of whether control center is armed or disarmed.	
X		X	
		ZONE REPAIRED (4) WITH CONTROL CENTER	
		ARMED	DISARMED
NO AUTO-RESET	When control center is disarmed (regardless of zone condition).	When control center is disarmed.	When control center is armed and disarmed again.

Table 2-9. Different types of restoral reporting.

**NOTES:**

(1) Restoral is reported for 24-Hour Zones (locations 207-208) at the times shown for Zone Restoral Report (right column). Restoral reporting is not recommended for Auxiliary Zone 1 if used for panic or Auxiliary Zone 2 if used for ambush.

Restoral is reported for a fire alarm or fire trouble (locations 184, 185) at the time the keypad FIRE/TROUBLE LED goes out. (See Keypad Operation chapter, "Hold-Down Function 9".)

Low-battery restoral is reported within 30 minutes of the time the battery is recharged or reconnected, whether the control center is armed or disarmed.

(2) Zone Restoral Report (locations 192-193) requires that Control Center Restoral Report (182-183) also be selected.

(3) Can be programmed for Zones 1 through 8 only.

(4) Zone-Restoral Zones or 24-Hour Zones should be programmed for Auto-Reset or Priority to prevent accidental auto-shunting of a latched zone.

Enter the restore code for each restoral reporting zone or condition in locations 048-077. A second digit for each restore code is entered with two-digit event code or extended format only. (See Data Format.)

See Alarm Time Out, Auto-Reset.

**SELECTIVE SHUNT (Locations 203-204)**

See Manual Shunting.

**SINGLE-DIGIT EVENT CODE FORMAT (Locations 113, 145)**

See Data Format.

**START EXIT DELAY AFTER CLOSING RINGBACK (Location 188)**

If a closing report is successfully transmitted to the central station, the Mini-Sounder will sound a 2-second "ringback" when the central station kissoff (verification signal) is received by the control-center communicator. The exit delay period can optionally be programmed to wait for this ringback before starting.

If the Start Exit Delay After Closing Ringback option is selected, and no ringback is heard after the control center is armed, the exit delay will not start, and opening the exit/entry door will cause an alarm. To manually start the exit delay, optionally disarm and (if programmed) test telephone line and communicator by holding down Key 6. Start the exit delay by entering the arming code then holding down Key 5 until the Mini-Sounder beeps, indicating that exit delay has started. Exit delay cannot be manually started a second time until the control center is disarmed and rearmed. (See KEYPAD OPERATION, Chapter 3.) NOTE: If communicator, telephone lines or central-station receiver require repair, the system will be armed without transmission capability.

To automatically start exit delay after closing ringback:

- (1) Add a 4 to location 188.
- (2) Select closing report (8 in location 181). Enter closing codes (locations 030-039) for each user (arm/disarm) code. (See Closing Report and Conditional Closing Report.)
- (3) Optionally enable Communicator Confidence Test with a 4 in location 189.
- (4) Alert the user that if no ringback is heard before leaving, the control center has not armed, and the procedure outlined in the Daily Operation portion of KEYPAD OPERATION (Chapter 3) should be followed.

Do not program Start Exit Delay After Closing Ringback if a conditional closing report is selected alone, without a closing report.

See Exit/Entry Delay. Also see Double Reporting, Back-Up Reporting.

**SUBSCRIBER IDENTIFICATION NUMBER (Locations 100-107, 108-111, 132-139, 140-143)**

Different subscriber identification numbers may be used to distinguish alarm/restore reports from opening and closing reports. (See Closing Report and Conditional Closing Report, Opening Report, Opening Report After Alarm, Report On Alarm/Restore.) Furthermore, different subscriber numbers may be assigned by the central station for each telephone number used. (See Double Reporting, Back-Up Reporting - location 186.)

Two alarm/restore identification numbers are available to divide group one alarms from group two alarms. The group one identification number will be used for reporting alarms on Zones 1 through 8. The group two identification number will be used for reporting alarms on the remaining zones.

Use Table 2-10 and the notes that follow it to program the required subscriber identification number locations. Enter at least 3 digits for each subscriber number used. (See Note 2 below the table for examples.) The central station will advise whether subscriber numbers are 3 or 4 digits long.

TELEPHONE NUMBER	SUBSCRIBER IDENTIFICATION NUMBER LOCATIONS: (1), (2)		
	ALARM/RESTORE I.D. GROUP 1 (3)	ALARM/RESTORE I.D. GROUP 2 (4)	OPENING/CLOSING I.D. (5)
1	100-103	104-107	108-111
2 (6)	132-135	136-139	140-143

Table 2-10. Program a separate subscriber identification number for opening/closing and alarm/restore reporting.

**NOTES:**

- (1) Subscriber numbers may be different or the same number. If the central station receiver cannot accept two-digit or extended event codes, single-digit alarm/restore codes may be reused as opening, closing codes by programming a different opening/closing subscriber number than the

subscriber number that is programmed to be sent with alarm and restore codes. Also, alarm groups one and two may have different subscriber numbers.

- (2) Enter at least 3 digits for each subscriber identification number used, even though the first and second digit may be zeros. (Examples are 001, 057.) The fourth digit is available for receivers capable of recognizing 4-digit subscriber codes.
- (3) Required for Report On Alarm/Trouble and Restoral Report for Zones 1 through 8 (locations 178-179, 182-183).
- (4) Required for Report On Alarm/Trouble and Restoral Report for remaining zones (locations 180-181, 184-185).
- (5) Required for Closing Report (8 in location 181), Opening Report (8 in location 185, Conditional-Closing Report, Conditional-Closing Status Report or Opening Report After Alarm (location 187)).
- (6) Required for Back-Up Reporting (location 186) and/or Double Reporting (location 186).

**SUM CHECK FORMAT** (Locations 113, 145)

See Data Format.

**TELEPHONE NUMBER** (Locations 114-131, 146-163)

Telephone number 1 (locations 114-131) is always programmed. Telephone number 2 (locations 146-163) is programmed if Back-Up Reporting or Double Reporting is selected. (See Double Reporting, Back-Up Reporting - location 186).

Each telephone number used will be preceded by at least a dial-tone detection entry ("E") or dial-delay entry ("d"), to ensure that the communicator detects dial tone or waits a reasonable delay to obtain a telephone line before dialing. (See Dial Tone Detection, Dial Delay.) Private telephone exchanges also require a separate, internal telephone line dial-tone detection or dial-delay digit, followed by an access number in order to obtain an outside line, followed by a second dial tone detection or dial delay for the outside line. (See Access Number For Outside Line.) Although the telephone number can start in location 115 (147 for telephone number 2), it is better to leave unused features blank for future changes. Some examples of alternate formats for programming telephone number 1 information are:

**Example 1: DIAL-TONE FREQUENCY + TELEPHONE NUMBER**

Locations: 114 117 - 119 120 - 126  
Entries: "E" + area code + telephone number  
or  
Locations: 114 115 117 - 119 120 - 126  
Entries: "E" + "1" + area code + telephone number

**Example 2: PRIVATE TELEPHONE EXCHANGE  
INTERNAL LINE DIAL-TONE DETECTION (OR DIAL DELAY) +  
TYPICAL ACCESS NUMBER DIGIT +  
EXTERNAL LINE DIAL-TONE DETECTION + TELEPHONE NUMBER**

Locations: 114 115 116 117 - 119 120 - 126  
Entries: "E" + "9" + "E" + area code + telephone number  
or  
Locations: 114 115 116 117 - 119 120 - 126  
Entries: "d" + "9" + "E" + area code + telephone number

**Example 3: NON-STANDARD EXCHANGE  
DIAL DELAY + TELEPHONE NUMBER**

Locations: 114 117 - 119 120 - 126  
Entries: "d" + area code + telephone number

Extra locations are provided to allow for any prefix telephone number digits required by various commercial telephone service vendors. These locations can also be used to correct errors in telephone number programming. To correct a telephone number programming error: (1) Substitute an "F" ([8] [PLUS] [7]) in the location containing the incorrect digit. The "F" will be ignored by the communicator when dialing. (2) Enter the correct digit in the next location following the "F".

**TIME SELECTION**

Note the suggested minimum (see Alarm Time Out) and maximum (see Exit/Entry Delay) values. Then use the instructions that follow to enter the number of minutes for each alarm time-out period and the number of seconds for exit and entry delays. **NOTE:** In the State of California, do not program Alarm Time Out for fire alarms.

- (1) Each time value has two consecutive programming locations.

The 1st location entry represents single seconds or minutes (up to 15). Program only the first location for times up to 15 seconds or minutes. For example, where permitted, a burglary alarm time out of 4 minutes would have a 4 in location 233 and a blank in location 234.

The 2nd location entry represents units of 16 seconds or minutes (up to 15 X 16 = 240). The total time period possible is 15 + 240 = 255 seconds or minutes.

The value 10 is entered as 0 (zero); the values 11 through 15 are entered as b, C, d, E, F, respectively.

- (2) The examples that follow show how to calculate the two entry numbers and enter them into the first and second locations for longer time periods.

**Example 1:** You want a fire alarm to stop signalling after 25 minutes. Divide 25 by 16: 25/16 = 1 and 9 left over. Enter a 9 in (1st) location 239 and a 1 in (2nd) location 240.

**Example 2:** You want an exit time of 45 seconds. Divide 45 by 16: 45/16 = 2 and 13 left over. Enter the letter "d" (which represents the number 13) in the 1st location (location 229) and a 2 in the second location (location 230).

- (3) Check your calculation before programming this way: Add the number in the 1st location to 16 times the number in the 2nd location. **NOTE:** If there is a "0" (zero) in a location, multiply by 10; if blank, multiply by 0.

Using Example 1: Multiply 16 X 1 (from location 240) = 16. Add 9 (from location 239) + 16 = 25 minutes.

Using Example 2: Multiply 16 X 2 (from location 230) = 32. Add 13 (represented by "d" in location 229) + 32 = 45.

239	240
1st	2nd
Location	Location
9	1

Example 1: Supervisory alarm time-out = 25 minutes

229	230
1st	2nd
Location	Location
d	2

Example 2: exit delay = 45 seconds

**TOUCH-TONE DIALING** (Location 186)

Select Touch-Tone Dialing only if the subscriber has touch-tone service. Touch-tone dialing is faster than, but not always as reliable as, rotary dialing.

To have the communicator use touch-tone every time it dials, add 1 to location 186.

Alternatively, to have the communicator use touch-tone on the first try, and change to rotary dialing if not successful, add 2 to location 106. Touch-

Tone Dialing will override Touch-Tone Rotary Backup if both are selected.  
**NOTE:** If Back-Up Reporting (location 186) is also programmed, the communicator will use rotary dial to reach telephone number 2.

TWO-DIGIT EVENT CODE FORMAT (Locations 113, 145)  
See Data Format.

ZONE RESTORAL REPORT (Locations 192-193)

Normally, Control-Center Restoral is programmed for a zone in order to send a restoral report to the central station. The report will be sent when either the zone is repaired or the control center is disarmed. If a restoral report is to be sent only when the zone is repaired, Zone Restoral should be selected (in addition to Control-Center Restoral). It is recommended that Auto-Reset and Priority or Priority with Bypass also be selected for proper operation. Also see Restoral Report.

4-SECOND DIAL DELAY (Locations 114, 146)  
See Dial Delay.

7 MILLISECOND LOOP RESPONSE (Locations 225-226)  
See Loop Response.

24-HOUR PROTECTION (Locations 207-208)

Generally, (a) Neither the green STATUS nor red ARMED/ALARM LEDs will indicate the condition of a zone programmed for 24-Hour Protection. Key 3 must be depressed to identify a 24-Hour Zone in a fault condition on the digital readout. (b) 24-Hour Protection Zones remain armed even though the control center may be disarmed. (c) If the control center is armed with a 24-Hour Zone in alarm, the Mini-Sounder will give a 2-second alert.

Burglary Zones 1 through 8 may be selected as 24-Hour Protection Zones.

Auxiliary Zones 1 and 2 are preprogrammed as 24-Hour Zones, and will give no keypad status or alarm LED indication.

**NOTE:** The Supervisory Zone is also preprogrammed as a 24-Hour Zone but has its own keypad LED (AUX.) reserved to indicate both trouble and alarm conditions on this zone.

50 MILLISECOND LOOP RESPONSE (Locations 227-228)  
See Loop Response.

## PROGRAMMING TROUBLESHOOTING GUIDE

Wiring and operation problems are covered in the Wiring Troubleshooting Guide included in INSTALLATION (Chapter 4). This part of Chapter 2 describes only programming problems.

### GENERAL SYMPTOMS

Specific symptoms occur at an installation. Many specific symptoms have the same causes. Instructions for these are grouped below as follows: General Symptom I results when a master PROM is incorrectly copied, General Symptom II results from custom installation programming problems.

**GENERAL SYMPTOM I: CONTROL CENTER AND COMMUNICATOR CANNOT FUNCTION (GENERALLY DUE TO MISSING OR INCORRECT BACKGROUND INFORMATION).**

#### POSSIBLE CAUSE REMEDY

Wrong PROM for Control Center.

- Check PROM order number, which should be DD493. If wrong, use a new DD493 PROM to make a new subscriber PROM.

**NOTE:** A master PROM may have been programmed with the features most commonly used at your installations. Both this master PROM and the PROM to be programmed as the subscriber PROM for a particular installation must be DD493 PROMs.

Bad PROM.

- If the PRO-410 Programmer LOCATION display had missing segments, the PROM may have been bad. Use a new DD493 PROM to make a new subscriber PROM. (If using a previously-programmed DD493 PROM in the master PROM socket, replace it, too.)

**GENERAL SYMPTOM II: CUSTOM PROGRAMMED FEATURES NOT OPERATING PROPERLY OR COMMUNICATOR INFORMATION NOT TRANSMITTING PROPERLY**

#### POSSIBLE CAUSE REMEDY

Feature or Communicator Information Not Programmed or Programmed Incorrectly.

- Check Programming Record Sheet against instructions in Glossary and correctly fill in all necessary location entry boxes.
- Compare PROM location(s) with correctly-completed Programming Record Sheet.
- If subscriber PROM is blank in required location(s) but correctly completed in other locations, program missing entries on existing subscriber PROM.
- If the PROM entry is *part* of the value needed (1, 2, 4, or 8 missing), but the remaining locations are correct, follow programmer instructions for *changing* PROM contents.
- If any PROM entry is larger than the required value, use a new DD493 PROM to make a new subscriber PROM.

## SPECIFIC SYMPTOMS

Specific symptoms describe problems that occur at individual installations.

### SYMPTOM: USER CANNOT PROGRAM ARM/DISARM CODES FROM KEYPAD

#### POSSIBLE CAUSE

#### REMEDY

Keypad Program Code Disabled.

- Normal function for high-security installations. If high-security keypad programming is selected with an 8 in location 189, press the START switch at the upper-left corner of control-center circuit board. Hold down Key 8 until the Mini-Sounder beeps, then enter keypad program code and choose arm/disarm and access control codes.

### SYMPTOM: CANNOT DISARM FOLLOWING POWER FAILURE/RESTORAL

#### POSSIBLE CAUSE

#### REMEDY

Control Center Wired to Restore in Armed Condition.

- Program fallback code (locations 249-252) and instruct user to enter code to disarm. NOTE: A lengthy power loss erases all keypad-programmed arm/disarm codes. Have user: (1) Push START switch. (2) Holding down Key 8, (3) enter keypad program code (locations 243-248). (4) Re-enter all arm/disarm and access codes.

### SYMPTOM: NO OUTPUT ON MINI-SOUNDER

#### POSSIBLE CAUSE

#### REMEDY

Bad PROM.

- Follow General Symptom I instructions.

### SYMPTOM: OPENING EXIT DOOR CAUSES ALARM

#### POSSIBLE CAUSE

#### REMEDY

Programmed to Start Exit Delay After Closing Ringback but Not for Closing Report.

- If it is desirable to start exit delay after closing report verified by central station kissoff (4 in location 188), closing report must be sent every time the system is armed, or the exit delay will be cancelled and the control center armed in the instant mode. Select closing report (8 in location 181) and enter closing codes (locations 030-045).

### SYMPTOM: FIRE DETECTORS DO NOT RESET FOLLOWING AN ALARM

#### POSSIBLE CAUSE

#### REMEDY

Detectors Wired, But Not Programmed, to be Reset by Control Center.

- Select Reset Output 2 Devices with a 2 in location 189.

**SYMPTOM: ALARM OUTPUT DEVICE DOES NOT SIGNAL ON ALARM**

POSSIBLE CAUSE

REMEDY

Alarm Outputs Not Selected for Zone.

- Check alarm output locations: Burglary siren (Terminals 42-43), selected in locations 216-218, device on Output 1 (Terminals 39 and 41 or 39 and 40), selected in locations 219-221; device on Output 2 (Terminals 34-36), selected in locations 222-224. If programmed incorrectly, follow instructions for General Symptom II.

**SYMPTOM: ALARM DEVICE DOES NOT TIME OUT**

POSSIBLE CAUSE

REMEDY

Alarm Time-Out Not Programmed for Alarm Output.

- Use Time Selection instructions to determine entry that should be in the following locations: Burglary or siren - 233-234; Fire (Supervisory) siren - 239-240; Output 1 - 235-236; Output 2 - 237-238. If necessary, follow instructions for General Symptom II.

**SYMPTOM: COMMUNICATOR LED\* DOES NOT GO OUT (RELAY DOES NOT ENGAGE) WHEN A ZONE IS TRIPPED**

POSSIBLE CAUSE

REMEDY

Zone Not Programmed to Report.

- If zone not selected to report on alarm/trouble (locations 178-181), follow instructions for General Symptom II.

Zone Contact Restores to Normal Faster than Programmed Loop Response.

- Burglary Zones 1-8 are preselected for 750-millisecond response. If zone restores in less than 750 milliseconds, program for faster loop response. Select 50 milliseconds in locations 227-228, 7 milliseconds in locations 225-226.

**SYMPTOM: COMMUNICATOR LED\* LIGHTS STEADILY FOR 12 SECONDS, THEN GOES OUT, (REPEATED TWICE) BEFORE BLINKING (ROTARY DIAL) OR LIGHTING STEADILY MORE THAN 12 SECONDS (TOUCH-TONE DIAL)**

POSSIBLE CAUSE

REMEDY

Dial-Tone Detection Not Programmed for Telephone Number.

- Program an "E" in location 116 for telephone number 1. If used, program an "E" in location 148 for telephone number 2. Follow instructions for General Symptom II.

\*The Communicator LED is located near the middle of the control-center board.



Dial-Tone Frequency Not 440Hz and Cannot be Recognized by Communicator.

- Use the instructions for General Symptom II to program a "d" in the first location of each telephone number used. If more than one 4-second delay period is needed before dialing, program more "d"s following the first. For non-standard exchanges, do not program the dial-tone detection "E" following the last pre-dial delay "d".

**SYMPTOM: COMMUNICATOR LED\* BLINKS (ROTARY DIAL) OR LIGHTS STEADILY FOR MORE THAN 12 SECONDS (TOUCH-TONE DIAL) 9 TIMES, BUT COMMUNICATOR DOES NOT REPORT**

POSSIBLE CAUSE

REMEDY

Telephone Number Not Programmed Correctly (receiver did not answer).

- Check locations 114-131 for correct telephone number 1. If used, check telephone number 2 locations 146-163. Follow instructions for General Symptom II.

**SYMPTOM: RECEIVER OR COMMUNICATOR NOT RECOGNIZING SIGNALS**

POSSIBLE CAUSE

REMEDY

Wrong or Missing Receiver Format or Data Format.

- Call central station for receiver format and data format. Use Glossary instructions for Receiver Format, Data Format, and General Symptom II instructions (above) to program receiver format and data format for each telephone number used.

**SYMPTOM: INCORRECT SUBSCRIBER IDENTIFICATION NUMBER AND ALARM CODE TRANSMISSION**

POSSIBLE CAUSE

REMEDY

Wrong or Missing Communicator Transmission Information.

- Call central station to verify: (1) Subscriber identification numbers. (a) telephone 1 - locations 100-107 (alarm/restore), 108-111 (opening/closing); (b) telephone 2 - locations 132-139, 140-143. (2) Alarm/trouble - locations 000-029. (3) Restore - locations 048-077. (4) Opening/Closing codes: (a) Closing - locations 030-045. (b) Conditional Closing codes - locations 046-047. (c) Opening - locations 078-093. Follow instructions for General Symptom II.

Noise on Telephone Line.

- Touch-tone dialing is not always as reliable as rotary dialing. It may be helpful to program the PROM (2 in location 186) to make the communicator automatically change to rotary dialing if touch-tone dialing does not succeed on the first attempt.

\*The Communicator LED is located near the middle of the control-center board.

**SYMPTOM: COMMUNICATOR SENDS 4 ROUNDS, THEN GOES ON HOOK 9 TIMES**

POSSIBLE CAUSE  
REMEDY

Wrong or Missing Receiver Format or Data Format.

- Call central station for receiver format and data format. Use Glossary instructions for Receiver Format, Data Format and General Symptom II instructions (above) for each telephone number used.

Sum Check Report Format Needed, but Not Programmed.

- Call central station. If Sum Check is required, follow instructions for General Symptom II to program Data Format (locations 113, 145) for Sum Check (4 in these locations).

**SYMPTOM: ZONE DOES NOT REPORT A RESTORAL AFTER PROBLEM REMOVED AND CONTROL CENTER IS DISARMED**

POSSIBLE CAUSE  
REMEDY

Zone Not Programmed for Zone-Restoral Report.

- If a zone-restoral report is desired for any Burglary Zones 1-8, zone must be selected in locations 192-193 and locations 182-185. Restore codes must be entered in locations 048-077.
- If a zone is selected for control-center restoral report (locations 182-185), but not for zone-restoral report (locations 192-193), or Auto-Reset (locations 209-210), the control center must be manually reset to send report.

**SYMPTOM: ABORT DELAY BEFORE DIAL FAILS TO OCCUR**

POSSIBLE CAUSE  
REMEDY

Abort Delay Selected on a 24-Hour Zone or Zone-Restoral Zone.

- If an alarm remains on a 24-Hour Zone or Zone-Restoral Zone for the duration of the abort-delay period, the communicator will report. To abort the report, repair the burglary devices/zones, then disarm the control center. Fire detectors must be reset with keypad Key 9.
- Check subscriber PROM locations 207-208 (24-Hour Protection); 192-193 (Zone Restoral) and 213-215 (Abort Delay).



Supervisory Zone automatically. The "1" (or any other number) in location 022 is therefore necessary to identify the zone. This leaves us with two zones with identical alarm codes. Zones 1 and 9 were chosen here since they often have similar features programmed.

Notice that Sum Check is programmed in location 113. This feature is recommended, when available, due to increased speed of transmission.

This example also applies to Ademco 685 receivers with revision 3.4 installed.

**Example 4. 4/2 Reporting.**

**PROGRAMMING RECORD SHEET (For MAGNUM ALERT-900)**  
COMMUNICATOR TRANSMISSION INFORMATION

ALARM/TROUBLE CODES		GROUP ONE										GROUP TWO																				
SINGLE DIGIT		000	001	002	003	004	005	006	007	008	009	010	011	012	013	014	015	016	017	018	019	020	021	022	023	024	025	026	027	028	029	030
EXTENDED OR TWO DIGIT		001	002	003	004	005	006	007	008	009	010	011	012	013	014	015	016	017	018	019	020	021	022	023	024	025	026	027	028	029	030	
RESTORE CODES		GROUP ONE										GROUP TWO																				
SINGLE DIGIT		000	001	002	003	004	005	006	007	008	009	010	011	012	013	014	015	016	017	018	019	020	021	022	023	024	025	026	027	028	029	030
EXTENDED OR TWO DIGIT		001	002	003	004	005	006	007	008	009	010	011	012	013	014	015	016	017	018	019	020	021	022	023	024	025	026	027	028	029	030	
OPENING/CLOSING CODES		CLOSING										OPENING																				
SINGLE DIGIT		000	001	002	003	004	005	006	007	008	009	010	011	012	013	014	015	016	017	018	019	020	021	022	023	024	025	026	027	028	029	030
EXTENDED OR TWO DIGIT		001	002	003	004	005	006	007	008	009	010	011	012	013	014	015	016	017	018	019	020	021	022	023	024	025	026	027	028	029	030	
ALARM/RESTORAL IDENTIFICATION		SUBSCRIBER I.D.										TELEPHONE NUMBER																				
GROUP ONE		100	101	102	103	104	105	106	107	108	109	110	111	112	113	114	115	116	117	118	119	120	121	122	123	124	125	126	127	128	129	130
GROUP TWO		130	131	132	133	134	135	136	137	138	139	140	141	142	143	144	145	146	147	148	149	150	151	152	153	154	155	156	157	158	159	160
KEYPAD CODES		AMBUSH										PROGRAM										FALLBACK										
AMBUSH		211 212										213 214										215 216										
PROGRAM		217 218										219 220										221 222										
FALLBACK		223 224										225 226										227 228										
ENTRY RECEIVER FORMAT		BLANK										ADEMCO, SLOW										SECORA VERTEX DCI & FRANKLIN*										
ENTRY DATA FORMAT		BLANK										EXTENDED OR SINGLE DIGIT										TWO DIGIT OR (4/2)										

Note that no two zones have the same alarm code. This is an advantage over Example 1, as the zones could never be confused during status reporting. If the ambush code were "B,9", only the second number (9) would be used during status ("F,9") and could be confused with Zone 9 status. The Supervisory Zone, Supervisory trouble, and low battery are not included in status reporting.

As noted in Example 1, when using BFSK, the Supervisory Zone is already understood as being a Fire Zone. Programming the "1" in location 022 is not required.

**Example 3. Radionics Fast, Not Software Compatible.**

**PROGRAMMING RECORD SHEET (For MAGNUM ALERT-900)**  
COMMUNICATOR TRANSMISSION INFORMATION

ALARM/TROUBLE CODES		GROUP ONE										GROUP TWO																				
SINGLE DIGIT		000	001	002	003	004	005	006	007	008	009	010	011	012	013	014	015	016	017	018	019	020	021	022	023	024	025	026	027	028	029	030
EXTENDED OR TWO DIGIT		001	002	003	004	005	006	007	008	009	010	011	012	013	014	015	016	017	018	019	020	021	022	023	024	025	026	027	028	029	030	
RESTORE CODES		GROUP ONE										GROUP TWO																				
SINGLE DIGIT		000	001	002	003	004	005	006	007	008	009	010	011	012	013	014	015	016	017	018	019	020	021	022	023	024	025	026	027	028	029	030
EXTENDED OR TWO DIGIT		001	002	003	004	005	006	007	008	009	010	011	012	013	014	015	016	017	018	019	020	021	022	023	024	025	026	027	028	029	030	
OPENING/CLOSING CODES		CLOSING										OPENING																				
SINGLE DIGIT		000	001	002	003	004	005	006	007	008	009	010	011	012	013	014	015	016	017	018	019	020	021	022	023	024	025	026	027	028	029	030
EXTENDED OR TWO DIGIT		001	002	003	004	005	006	007	008	009	010	011	012	013	014	015	016	017	018	019	020	021	022	023	024	025	026	027	028	029	030	
ALARM/RESTORAL IDENTIFICATION		SUBSCRIBER I.D.										TELEPHONE NUMBER																				
GROUP ONE		100	101	102	103	104	105	106	107	108	109	110	111	112	113	114	115	116	117	118	119	120	121	122	123	124	125	126	127	128	129	130
GROUP TWO		130	131	132	133	134	135	136	137	138	139	140	141	142	143	144	145	146	147	148	149	150	151	152	153	154	155	156	157	158	159	160
KEYPAD CODES		AMBUSH										PROGRAM										FALLBACK										
AMBUSH		211 212										213 214										215 216										
PROGRAM		217 218										219 220										221 222										
FALLBACK		223 224										225 226										227 228										
ENTRY RECEIVER FORMAT		BLANK										ADEMCO, SLOW										SECORA VERTEX DCI & FRANKLIN*										
ENTRY DATA FORMAT		BLANK										EXTENDED OR SINGLE DIGIT										TWO DIGIT OR (4/2)										

A receiver capable of utilizing this format allows greater flexibility when choosing codes. The first location may describe the type of alarm:

- 3 = Burglary
- 6 = Trouble
- 5 = Opening
- 4 = Closing

The numbers you choose may be different. The second location indicates the zone or user number. An alarm on Zone 2 and Aux Zone 2 would be received as:

Acct 0001 32  
Acct 0001 22

This example illustrates the inability of formats other than BFSK to identify the

If status were programmed and the system armed with these zones auto-shunted, the following would be received:



If a zone with alarm code "9" sends a status report and the conditional closing code is an "F", the status report will look like a low battery. This is why the Ambush Zone was chosen as alarm code 9; a status report is not typical on this zone.

Letters may be used as zone alarms because they are not converted to fast format. For example, the trouble zone D will be received and printed as "001,D". Letters cannot be used in second locations, "E,F" for example, because the extended format will be converted to fast format and the "F" will be seen as Zone 15 (and there are only eight zones!). Be sure when using status reporting that the conditional closing code "F" is not expanded with an alarm code higher than 8.

**PROGRAMMING RECORD SHEET (For MAGNUM ALERT-800)**  
COMMUNICATOR TRANSMISSION INFORMATION

ALARM/TROUBLE CODES	SIGNAL TYPE															
	3	5	4	5	6	7	8	9	0	1	F	d	F	d	F	d
SINGLE DIGIT	3	5	4	5	6	7	8	9	0	1	F	d	F	d	F	d
EXTENDED OR TWO DIGIT	301	505	406	507	608	709	810	911	012	113	F14	d15	F16	d17	F18	d19

RESTORE CODES	SIGNAL TYPE															
	3	5	4	5	6	7	8	9	0	1	F	d	F	d	F	d
SINGLE DIGIT	3	5	4	5	6	7	8	9	0 <td>1<td>F</td><td>d<td>F</td><td>d<td>F</td><td>d </td></td></td></td>	1 <td>F</td> <td>d<td>F</td><td>d<td>F</td><td>d </td></td></td>	F	d <td>F</td> <td>d<td>F</td><td>d </td></td>	F	d <td>F</td> <td>d </td>	F	d
EXTENDED OR TWO DIGIT	33	55	44	55	66	77	88	99	00	11	F1	d1	F1	d1	F1	d1

OPENING/CLOSING CODES	CLOSING								OPENING							
	1	2	3	4	5	6	7	8	1	2	3	4	5	6	7	8
SINGLE DIGIT	C	C	C	C	C	C	C	F	F	F	F	F	F	F	F	
EXTENDED OR TWO DIGIT	11	22	33	44	55	66	77	11	22	33	44	55	66	77	88	

ALARM/RESTORATION IDENTIFICATION	SUBSCRIBER I.D.	OPENING/CLOSING IDENTIFICATION	FORMAT RECEIVER DATA	NO-DIAL RELAY	NOCALL	DIAL TIME	TELEPHONE NUMBER																								
							1	2	3	4	5	6	7	8	9	0	1	2	3	4	5	6	7	8	9	0					
GROUP ONE	100	101	102	103	104	105	106	107	108	109	110	111	112	113	114	115	116	117	118	119	120	121	122	123	124	125	126	127	128	129	130
GROUP TWO	131	132	133	134	135	136	137	138	139	140	141	142	143	144	145	146	147	148	149	150	151	152	153	154	155	156	157	158	159	160	

KEYPAD CODES	SIGNAL TYPE															
	3	5	4	5	6	7	8	9	0	1	F	d	F	d	F	d
AMBUSH	3	5	4	5	6	7	8	9	0	1	F	d	F	d	F	d
PROGRAM	3	5	4	5	6	7	8	9	0	1	F	d	F	d	F	d
#ALL BLANK	3	5	4	5	6	7	8	9	0	1	F	d	F	d	F	d

ENTRY	RECEIVER FORMAT	DATA FORMAT
BLANK	ADEMCO, SLOW	EXTENDED OR SINGLE DIGIT
1	SEBOSA VERTEX DCI & FRANKLIN*	SINGLE DIGIT
2	HANDHOLD, FAST	TWO DIGIT OR (4D)
3	SILENT KNIGHT, FAST	BUM CHECK
4	HANDHOLD, DCI FRANKLIN, SLOW*	
5	(RESERVED)	
6	(RESERVED)	
7	HANDHOLD, BFBK	
8		

\* THESE FORMATS TYPICALLY USE A 2800 Hz HANDSHAKE (ADD AN # TO THIS ENTRY)  
\*\* TWO DIGIT FORMAT ONLY.

The expanded codes for openings and closings will always be understood by an Ademco receiver with revision 3.4 installed when using a "B" or "C" in the first location. However, an expanded "E" or "F" will only be understood when the English-language messages and zone English-language options on the receiver are not used. Otherwise, with a restore code of "E,5" for example, "001,E" will be received fine as a restore but the "EEE,9" will be seen as an error. The letter "D" can be used as an alarm code or expanded at any time since it is usually undefined.

## KEYPAD OPERATION

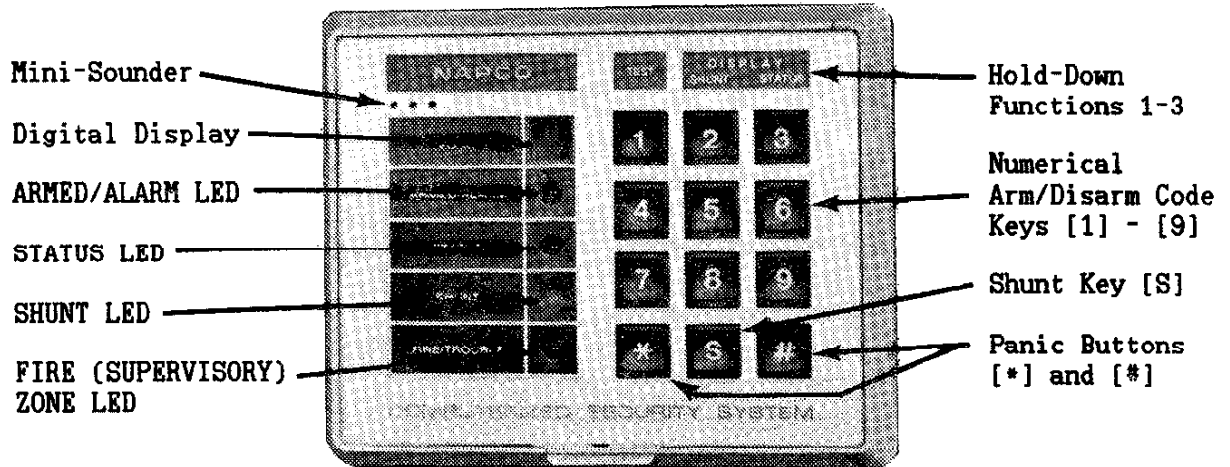

Fig. 3-1. Keypad front panel.

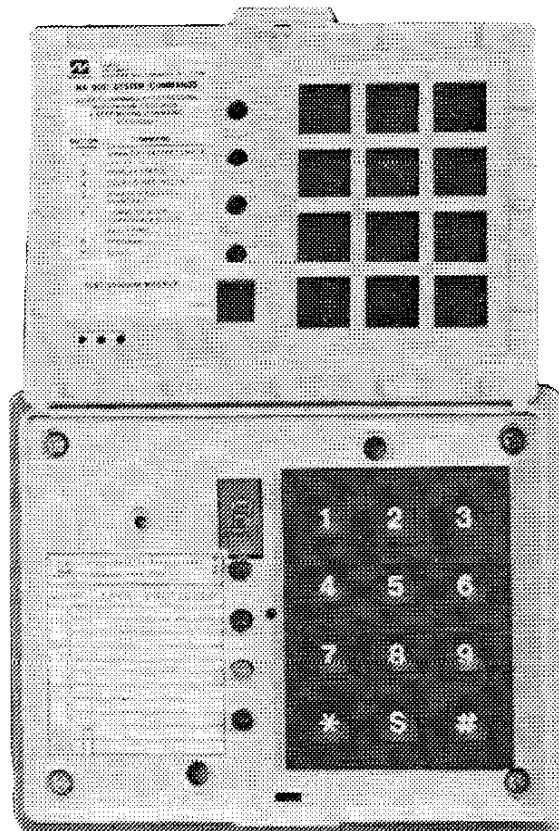

Fig. 3-2. Lift front panel to expose labels for Hold-Down Functions 4-9.

## INDICATORS

### Red (ARMED/ALARM) LED

Steady glow - Control center is armed.

Slow blink - Alarm on non-24-Hour Burglary Zone. Alarm zone numbers appear on the digital display.

Rapid blink - Exit/entry delay cancelled with Key 4. All zones are instant.

### Green (STATUS) LED (when disarmed)

Steady glow - All non-24-Hour Burglary Zones are functioning normally.

Blinks every second - Trouble exists on at least one non-24-Hour Zone.

Blinks rapidly - Day Supervision Zone trouble.

### Yellow (SHUNT) LED

Steady glow - At least one zone manually shunted.

### Bottom Red (AUX) LED

Steady glow - Alarm on the Supervisory Zone.

Blinking - Trouble on the Supervisory Zone.

### ARMED/ALARM, STATUS, SHUNT LEDs blinking together

Slow blink (while disarmed) - Ac power loss.

Rapid blink (and Mini-Sounder pulsing) - Keypad Program Mode enabled.

### Digital Display

Flashing zone number(s) 1 to 9 - Non-24-Hour Zone in alarm condition or Day Supervision Zone trouble.

Hold down Key 3 to display any zone including 24-Hour Zone(s) in fault condition.

Displays zero (and Mini-Sounder on) - Unsuccessful attempt to arm with Priority Zone trouble, display memory not reset after alarm/trouble, or an ac power loss that (if programmed) has not been bypassed.

### Mini-Sounder

Immediately after arming code entered:

Continuous, steady - Priority condition. System cannot arm. Disarm to silence sounder.

2-second, steady - Unshunted zone in trouble, 24-Hour Zone latched in fault condition, or low-battery condition exists. Hold down keypad Key 3 to display zone number(s).

Following brief delay after arming code entered:

3-second, steady - "Ringback" verifies closing report received.

On reentry: Continuous, steady - Entry delay period in progress.

Pulsing:

With digital display - Day-Zone trouble (if Day-Zone audible warning not disabled by programming).

And bottom red LED on - Supervisory-Zone alarm/trouble.

Hold down Key 9 to silence alert.

## KEYS

### Numerical Keys:

Code entry - Press Key 8 briefly to enter program code, program up to 8 arm/disarm codes and access control code, arm/disarm with programmed codes or fallback code, release door with access control code.



**Tamper Lockout** - If wrong code pressed to arm/disarm, keypad locks. Wait 2 seconds before trying again.  
**Ambush alarm (if programmed)** - Press 2-digit Ambush Code, then disarm code.  
**Hold-down function** - To enable, press key until Mini-Sounder beeps.  
**Alarm reset** - Disarm to silence an alarm sounding device.

**[\*] and [\*] Keys:**

Press at the same time to signal panic alarm .

**[S] Key (if programmed):**

**Shunting** - Shunt when disarmed. Press S then zone number to bypass (shunt) a zone programmed for selective shunt. Press S twice to bypass all zones programmed for group shunt. Yellow LED lights when zones are manually shunted. Hold down Key 2 to display manually shunted zones.

**Cancelling Shunt** - Disarm.

### HOLD-DOWN FUNCTIONS

Numerical keys have secondary functions, called "hold-down" functions. Hold-down functions for Keys 1 through 3 are labelled on the keypad front panel. Raise the front panel to expose the remaining hold-down function key labels. To use any key's secondary function, hold that key down for approximately 2 seconds, until the Mini-Sounder beeps briefly.

#### Hold-Down Function 1: TEST

**Standby battery test:** Hold down Key 1 until the beep is heard. The burglary alarm will sound while the control center is powered by the standby battery. If no alarm is heard, or the alarm is weak, the battery may need recharging or replacement (see INSTALLATION chapter: Standby Battery). The battery should be tested weekly.

#### Hold-Down Function 2: DISPLAY SHUNT

To digitally display the numbers of all the zones shunted with the [S] key, hold down Key 2 until the Mini-Sounder beeps.

#### Hold-Down Function 3: DISPLAY STATUS

Hold down Key 3 until the Mini-Sounder beeps. The numbers of any of the Burglary Zones 1 through 9 in trouble will appear on the keypad digital display.

#### Hold-Down Function 4: INSTANT PROTECTION

Normally, entering the arming code will begin the exit delay period. No alarm will sound if the exit/entry door is closed before the end of the exit delay time. No alarm will sound the next time the exit/entry door is opened, until the end of the entry delay time.

If the premises are to be occupied while the control center is armed, the exit/entry delays may be cancelled, causing an alarm to sound instantly if the exit/entry door is opened. Hold down Key 4 until the Mini-Sounder beeps. If the control center is disarmed, enter the arming code after the beep (or arm and disarm to cancel). The red ARMED/ALARM LED will blink steadily and rapidly as long as the control center is armed with instant protection. Disarming the control center cancels instant protection.

#### Hold-Down Function 5: START EXIT DELAY WITHOUT RINGBACK

If the communicator is programmed to send a closing report at the time the control center is armed, the central station sends a kissoff (verification) signal, which causes 2-second Mini-Sounder "ringback" to be heard after arming. (Closing report is selected with an 8 in PROM location 181.) If the exit delay period is programmed to automatically begin following the kissoff (4 in PROM location 188), and no ringback is heard, the exit delay period will not begin, the exit follower zones (if programmed) will not arm, and opening the exit/entry door will cause an entry delay warning.

Optionally, reenter the arm/disarm code to cancel the arming request and follow the instructions for Communicator Confidence Test ("Hold-Down Function 6") to determine whether the communicator or telephone lines require service.

It is still possible to start the exit delay period: If disarmed, enter the arming code. Hold down Key 5 until the Mini-Sounder beeps. The exit delay will start. The exit delay cannot be manually started a second time until the control center is disarmed and re-armed.

**NOTE:** If communicator, telephone lines or central-station receiver require repair, the system will be armed without transmission capability.

#### Hold-Down Function 6: COMMUNICATOR CONFIDENCE TEST

If Communicator Confidence Test is programmed (4 in PROM location 189), holding down Key 6 while the control center is still disarmed will test the communicator's ability to dial out. The Mini-Sounder will pulse rapidly while the communicator attempts to detect a dial tone. If successful, the Mini-Sounder goes off, indicating telephone lines are operating properly. If the Mini-Sounder goes on steadily, hold down Key 9 to silence the sounder and try to dial out over a voice line. If unable to dial out, the telephone lines may be faulty. If successful, the communicator may not be operating properly.

#### Hold-Down Function 7: FAULT FIND

While the control center is disarmed, holding down Key 7 until the Mini-Sounder beeps will cause Zones 1 through 9 to respond within 7 milliseconds. If a problem is detected on Zones 1 through 9 and supervisory trouble and then corrected, the Mini-Sounder will sound for a few seconds as the zone restores to normal. This aid can be applied as follows:

- (1) The installer or service person can check each loop's continuity by purposely and momentarily causing detection. (For example, opening and closing windows or doors will test open-circuit detection. Banging on surfaces close to wires and detection devices will uncover "swingers".) If the Mini-Sounder is heard, the loop has momentarily experienced trouble and restored. **NOTE:** Supervisory trouble will still have a 10-second delay.
- (2) If the green STATUS LED blinks momentarily every 2 seconds when the system is disarmed, or the Mini-Sounder signals on arming, the end-user can hold down Key 3 to identify a faulty Burglary Zone, then disarm, (if armed), press Key 7 and attempt to repair the zone (for example, by closing an open window). If the zone restores successfully, the Mini-Sounder will signal. When all trouble has been removed from the system, the user can arm with full protection.

Arming the control center cancels the fault-find function.

#### Hold-Down Function 8: PROGRAM

The three- to six-digit PROM-programmed keypad program code (locations 243-248) authorizes the user to choose up to 8 arm/disarm codes and an access control code through the keypad.

Generally, the user holds down Key 8 until the Mini-Sounder beeps, then, within 8 seconds, presses the PROM-programmed keypad program code numbers. **Exception:** If high-security keypad programming is selected with an 8 in PROM location 189, the user must press the START switch at the upper-left corner of the control-center circuit board *before* pressing Key 8, then press the keypad program code numbers on the keypad within 4 minutes. **WARNING:** If a tamper switch is installed on the control-center door, opening the door to gain access to the START switch may cause a tamper alarm.

The top three keypad LEDs and the Mini-Sounder will pulse while the user enters arm/disarm and access control codes, using the following sequence of keys:

[S] + [1] + two to four digits, assigning first user arm/disarm code.  
[S] + [2] + second user arm/disarm code.  
[S] + [3] + third user arm/disarm code.  
[S] + [4] + fourth user arm/disarm code.  
[S] + [5] + fifth user arm/disarm code.  
[S] + [6] + sixth user arm/disarm code.  
[S] + [7] + seventh user arm/disarm code.  
[S] + [8] + eighth user arm/disarm code.

The number following the [S] determines which opening or closing user code will be transmitted (if reporting is programmed).

**NOTE:** If an arm/disarm code is entered that has the first two digits identical to the ambush-code sequence, that code will only be able to arm the system and *not* disarm. This may be useful with users who do not have the authority to disarm. When used, this "arm only" code will not send an ambush alarm.

[S] + [9] + two to four digits, assigning access control code.

The access control code is used by those persons authorized to enter the premises without first being identified by someone inside the premises who must release the access door. An electric door switch must be connected to the access door. (See INSTALLATION, Chapter 4, "Terminals 39-40: Output 1".) Pressing the access code activates the door switch, releasing the door.

[S] + [S] ends the keypad programming session. The LEDs and Mini-Sounder will go off.

**WARNING:** If the control center loses power, or the START switch on the control-center circuit board is pushed, all arm/disarm codes and the access control code will be erased. If available, the fallback code (PROM locations 249-252) may be used to arm or disarm. Arm/disarm and access control codes must be reentered using the keypad program authorization code.

#### Hold-Down Function 9: RESET/BYPASS

Key 9 has several hold-down functions.

#### Supervisory Zone Function:

**Detection-Device Reset.** The Supervisory Zone is usually used to monitor such installation conditions as temperature or essential equipment functioning. Trouble and alarm conditions on this zone are indicated on the separate, lowermost red LED on the keypad.

**Supervisory Zone Trouble.** A trouble condition on the Supervisory Zone will cause the bottom red LED to blink and the Mini-Sounder to pulse after a 10-second delay. To silence the sounder, hold down Key 9 until the Mini-Sounder beeps. The LED will continue to blink. The Fault-Find mode may be used to annunciate when the trouble is repaired. After the zone is repaired,

hold down Key 9 again to turn off the LED. Trouble on this zone will not affect the green STATUS LED.

**Fire (Supervisory) Zone Alarm.** An alarm condition on this zone will cause the bottom red LED to glow steadily and the Mini-Sounder to pulse, and will activate the fire alarm. Hold down Key 9 to silence the sounder. The LED will stay on.

Wait 8 seconds after silencing the Mini-Sounder, then hold down Key 9 again until the Mini-Sounder beeps. If the LED remains on, a thermostat has not cooled, or a smoke detector has not cleared. Hold down Key 9 approximately every 8 seconds until the detectors return to normal. The LED will go out when the detectors and the zone successfully reset.

If the alarm has not timed-out, (fire alarm time out period is programmed in PROM locations 239-240), silence the alarm by disarming the control center.

If this zone monitors a condition other than fire, silence the Mini-Sounder, repair the alarm condition, then hold down Key 9 a second time to turn off the alarm LED. If the alarm has not timed-out, disarm the control center to silence the alarm.

It is recommended that Priority (location 200) be programmed for the Fire Zone to prevent accidental auto shunting.

Day-Zone Trouble Indication Reset: During the day, when the control center is not armed, if a zone programmed for Day Zone (PROM locations 194-195) becomes open or shorted, the Mini-Sounder will pulse (unless audible Day Zone warning is disabled by programming an 8 in location 188), the green STATUS LED will flash rapidly, and the zone number will be displayed on the digital readout. Hold down Key 9 to turn off the visual and audible indicators. The green STATUS LED will blink on briefly every second as long as a zone requires service. After all trouble is repaired, the green LED will come on steadily again, indicating that all zones are functioning properly. However, once a Day Zone has indicated trouble and been repaired, the same zone cannot indicate a second open or short-circuit condition until the control center has been armed and disarmed again.

Arming With No Ac Power: If ac power fails while the control center is disarmed, the top three keypad LEDs blink together slowly. The control center can be armed while powered by the standby battery. Test the standby battery: (1) Hold down Key 1 and wait for the burglary alarm to sound, indicating that the battery is operating. (2) Hold down Key 9 until the Mini-Sounder beeps, then enter the arming code.

Priority With Bypass: If a trouble exists on Zones 1 through 8 selected for Priority With Bypass, a priority condition will occur (constant Mini-Sounder on and a zero displayed at the keypad). Holding down Key 9 will bypass this condition so that the panel can be armed.

## DAILY OPERATION

### SELECTING ARM/DISARM CODES, ACCESS CONTROL CODE

- (1) Enter Program Mode: Hold down Key 8 until the Mini-Sounder beeps, within 8 seconds, enter keypad programming authorization code. (Exception: If high-security programming is selected, push the START switch on the control-center circuit board before holding down Key 8. Caution: Opening door may cause a tamper alarm.)  
The top three keypad LEDs and the Mini-Sounder will pulse rapidly.
- (2) Select Arm/Disarm Codes: Press [S], then [1], then two to four digits for the first valid arm/disarm code. Optionally select the second through the eighth arm/disarm codes: press [S], then an order number ([2] to [8]), then two to four digits for each arm/disarm code.
- (3) Optionally Select Access Control Code: (Generally for commercial installations.) To authorize access door to be released press [S], then [9], then two to four digits for the code. (Electric door switch must be connected to Terminals 39-40 to release the door.)
- (4) End Programming Session: Press [S] two times. The LEDs and Mini-Sounder will go off.

### ARMING WHEN LEAVING

- (1) Check Power: If top three keypad LEDs blink together slowly, system has no ac power. Check for disconnected transformer. Test standby battery: Hold down Key 1, wait for bell or siren to sound.

Check for Burglary-Zone Trouble: If green STATUS LED blinks on briefly every second, hold-down Key 3 to display number(s) of zone(s) in trouble. Hold down Key 7 until Mini-Sounder beeps. Correct trouble, if possible by closing open doors or windows. Mini-Sounder will beep again if a problem is fixed.

- (2) Arm: Close all doors and windows connected to Zone 9. If necessary, hold down Key 9 to arm without ac power. Enter arming code on numerical keys. NOTE: If the wrong code is pressed to arm/disarm, wait 2 seconds before entering code again.

Listen for Problem Alert (and hold down Key 3 to display problem zone numbers): If Mini-Sounder signals steadily for 2 seconds, and the red ARMED/ALARM LED is on, the system is armed without protection from auto-shunted and/or problem 24-Hour Zone(s), or with a low-battery condition. If Mini-Sounder sounds continuously while a zero is displayed, a Priority Zone is in trouble, and the system cannot be armed. Enter disarm code. If an alarm signals on arming, a non-Auto-Shunt Zone is in trouble. Disarm, repair zone, arm and disarm again to reset control center. Then arm with protection restored.

- (3) Wait for Ringback: If exit delay is programmed to start after closing ringback, wait for the Mini-Sounder signal. If there is none, (a) check communicator and telephone line (if communicator confidence test is programmed); disarm, hold down Key 6 and (b) manually start exit period -- enter arming code (if disarmed), hold down Key 5 until the Mini-Sounder beeps.
- (4) Leave Quickly: If the Mini-Sounder goes on steadily, the exit period has ended and the entry period has begun: disarm quickly, arm again and leave during the next exit delay.

## PROTECTING OCCUPIED PREMISES

### ARMING

- (1) Check Power: If top three keypad LEDs blink together slowly, system has no ac power. Check for disconnected transformer. Test standby battery. Hold down Key 1 and wait for bell or siren to sound. Close all doors and windows connected to Zone 9.

Check for Perimeter-Zone Trouble: If green STATUS LED blinks on briefly every 2 seconds, hold-down Key 3 for digital display of trouble-zone numbers. Hold down Key 7 until Mini-Sounder beeps. Correct trouble, if possible. Close any open doors or windows; Mini-Sounder will beep again if a problem is fixed.

- (2) Shunt (Disable) Interior Zones: Press [S] then a zone number to selectively shunt one zone. Press [S] twice to shunt all program-selected group-shunt zones. Hold down Key 2 to identify shunted zones. To reactivate manually-shunted zones, disarm.
- (3) Cancel Exit/Entry Delay: Hold down Key 4 and enter arming code for instant protection. (Disarm to cancel instant protection.)
- (4) Arm: If necessary, hold down Key 9 to arm without ac power. Enter user arming code on numerical keys.

Listen for Problem Alert: If Mini-Sounder or alarm signals, hold down Key 3 to display any problem perimeter-zone numbers. Disarm, repair zone, arm and disarm again to reset control center. Then arm with perimeter protection restored.

### SIGNALLING A PANIC EMERGENCY ALARM

Press the [\*] and [#] keys at the same time.

### DISARMING

#### DISARMING ON RETURNING, BEFORE ARMING TO LEAVE, OR AFTER AN ALARM

- (1) Check for Burglary Alarm: If ARMED/ALARM LED flashes, note the numbers of any alarm zones on the digital display. LED will not flash for 24-Hour Zones: hold down Key 3 to display the numbers of any 24-Hour Burglary Zones in fault condition.
- (2) Check Condition of Fire (Supervisory) Zone: If Mini-Sounder pulses, and the bottom red LED is on, hold down Key 9 to silence the sounder. If bottom red LED lights steadily (alarm condition) and this zone is used for fire, hold down Key 9 every 8 seconds until the detectors cool or clear of smoke and reset, and the LED goes off. If bottom red LED lights steadily and the zone is supervising a condition other than fire, repair the problem, then hold down Key 9 to turn off the LED and reset the zone. If the fire siren does not time out, arm and disarm again to silence the alarm.
- (3) Disarm: (If entering, disarm before the steady Mini-Sounder signal stops.) Enter disarm code on keypad.

#### REPORTING AN AMBUSH TO THE CENTRAL STATION (if programmed)

If an intruder forces disarming, enter the ambush code, then, within 8 seconds, the user disarm code on the keypad.

## LOCATING PROBLEMS WHEN DISARMED

- (1) Check for Ac Power: If top three LEDs on keypad blink together slowly, check for general power outage or disconnected transformer. *Check for low-battery condition weekly.* Hold down Key 1 until the burglary alarm signals.
- (2) Check for Fire (Supervisory) Zone Trouble: If the bottom red LED and Mini-Sounder pulse, hold down Key 9 to turn off sounder. Optionally, use fault find (Hold-Down Function 7) to annunciate when the trouble is repaired. After zone is repaired, hold down Key 9 again to turn off blinking fire/trouble LED.
- (3) Check for Burglary-Zone Trouble: If the green STATUS LED blinks on briefly every second, hold down Key 3 to identify trouble zones on the digital display.
- (4) Locate Day-Zone Trouble (if programmed): If a Day Supervision Zone is in trouble, the Mini-Sounder (if audible Day-Zone indication not disabled by programming) and green STATUS LED will pulse, and the trouble-zone numbers will be displayed. Hold down Key 9 to turn off the indicators. The green LED will blink on briefly every second until all zone trouble is repaired.
- (5) Locate Faults: Hold down Key 7 until Mini-Sounder beeps. Zones 1 through 9 will now respond within 7 milliseconds. Verify zone restoral: Open and close windows and doors. Stand on floor mats. Walk in front of ultrasonic and infrared detectors. Each time a zone detects a problem and successfully restores, the Mini-Sounder will signal briefly. Check for "swingers" by striking surfaces surrounding wiring, contacts, window foil, etc. several times. If the Mini-Sounder signals, the wiring or detection device is intermittently opening and closing the circuit in response to vibration. Repair any faulty connections. *Return zone response times to normal* by entering code to arm the system.

## INSTALLATION

### CONTROL-CENTER MOUNTING

(See **KEYPAD MOUNTING** and template for mounting keypad onto a wall.)

Choose a location accessible to (a) a continuously-powered ac source (that cannot be shut off with a wall switch), (b) a cold-water-pipe ground, ideally no further away than 10 feet, and (c) telephone lines. Remove appropriate knockouts for cable runs. Place the control center at a convenient viewing height and mark the mounting holes.

At least one keypad should be located near the exit/entry door. If another keypad or a keyswitch station is to be mounted at the control center, remove the rectangular knockout on the control-center door. Backplate mounting is available for remote keypads; junction box mounting is available for remote keypads and keyswitch stations. **NOTE:** RP-1009 remote stations will not fit standard double-gang boxes. (See **ORDERING INFORMATION.**)

### GROUNDING

Connect the control-center ground screw to a metal cold-water pipe. Do not use a gas pipe, plastic pipe, or ac ground connections. Use at least 16 gauge wire. Make as short and direct a run as possible, without any sharp turns in the wire.

### TYPICAL FIRE INSTALLATION

At least one smoke detector should be installed directly outside each sleeping area. If there is more than one floor, additional smoke detectors should be installed on each level, including the basement. The living-area and basement smoke detectors should be installed near the stairway of the next upper level.

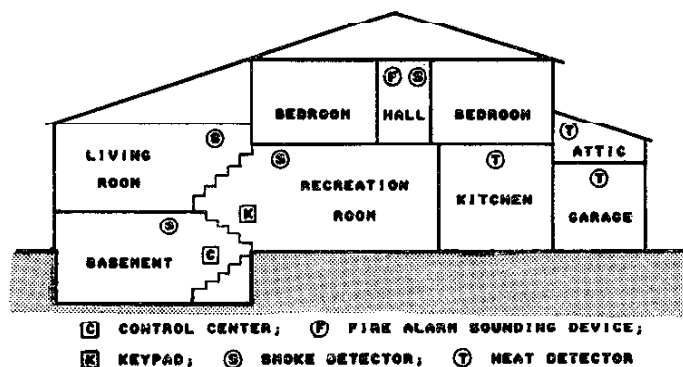

Fig. 4-1. Typical fire installation.

For increased protection, additional detectors should be installed in areas other than those required, such as dining rooms, individual bedrooms, furnace rooms, utility rooms and hallways. Heat detectors, rather than smoke detectors, are recommended in garages, attics, and kitchens due to conditions that may result in false alarms and improper operation. Large areas and areas with partitions, ceiling beams, doorways, and open joists will require additional detectors. Refer to NFPA Standard 74 (National Fire Protection Association, Batterymarch Park, Quincy, MA 02269) for additional information, including proper mounting of detectors.

### SELECTING WIRING FEATURES

Wiring features must often also be programmed in the PROM. PROM features should be listed, when programmed, on the Installation Record label (Fig. 2-1) and that record pasted inside the control-center cabinet door for reference purposes when wiring.

After wiring and testing are completed, complete the Installation Record. Fill in the **AREA PROTECTED** and **ZONE DEVICES** columns for each zone as a record of wiring options used. Date and sign it at the top.



Fig. 4-2. Wiring Diagram

4-2

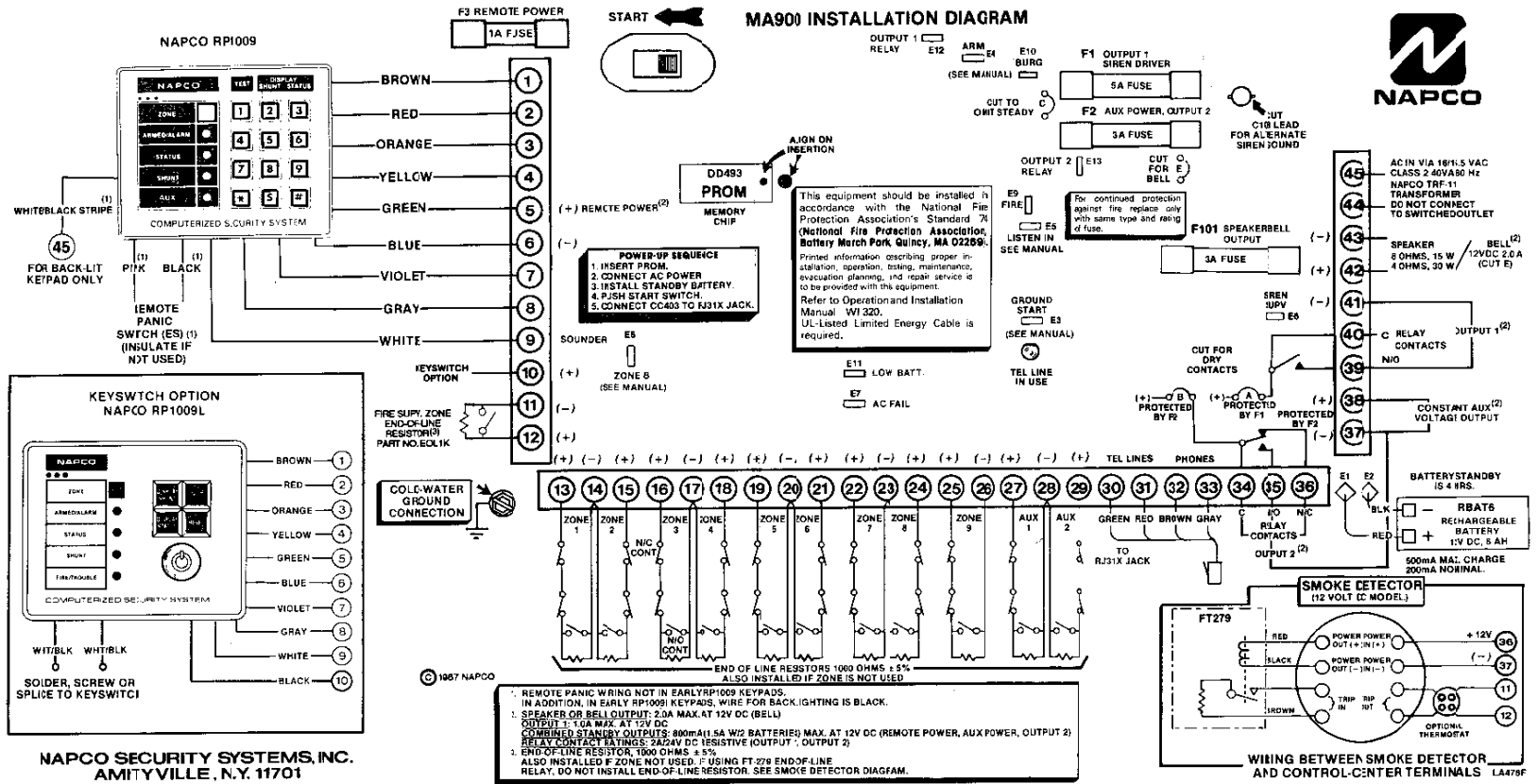

MA900 INSTALLATION DIAGRAM

This equipment should be installed in accordance with the National Fire Protection Association's Standard 74 (National Fire Protection Association, Battery March Park Quincy, MA 02269). Printed information describing proper installation, operation, testing, maintenance, evacuation planning, and repair service is to be provided with this equipment. Refer to Operation and Installation Manual WJ 320. UL-Listed Limited Energy Cable is required.

REMOTE PANIC WIRING NOT IN EARLY RP1009 KEYPADS. IN ADDITION, IN EARLY RP1009 KEYPADS, WIRE FOR BACK LIGHTING IS BLACK. SPEAKER OR BELL OUTPUT: 2.0A MAX. AT 12V DC (BELL) OUTPUT 1: 1.0A MAX. AT 12V DC COMBINED STANDBY OUTPUTS: 400mA (1.5A W/2 BATTERIES) MAX. AT 12V DC (REMOTE POWER, AUX POWER, OUTPUT 2) RELAY CONTACT RATINGS: 2A/24V DC RESISTIVE (OUTPUT 1, OUTPUT 2) END-OF-LINE RESISTOR, 1000 OHMS, ± 5% ALSO INSTALLED IF ZONE NOT USED, F USING FT-279 END-OF-LINE RELAY, DO NOT INSTALL END-OF-LINE RESISTOR. SEE SMOKE DETECTOR DIAGRAM.

## TERMINAL CONNECTIONS

### TERMINALS

### WIRING INFORMATION (See Fig. 4-2)

1 to 11

#### Arming Options

One RP-1009 keypad is supplied with, and must be connected to, each MAGNUM ALERT-900 control center. A maximum of 9 additional keypads or RP-1009L keyswitch stations (with momentary keyswitches) may be added if suitable gauge wiring is used. Do *not* use maintained keyswitches.

Note that total combined standby outputs (Remote Power, Constant Auxiliary Power, and Output 2) is 800mA maximum. Remote power is the power to the keypad. Each keypad nominally draws 50mA.

1 to 9

#### (1) RP-1009 Digital Keypad

The keypad is essential to the MAGNUM ALERT-900 installation. It provides remote arming and disarming, and is the vehicle through which the user communicates with the control center and monitors system status. (See KEYPAD OPERATION chapter.)

Wire keypads in parallel with the terminals shown in Fig. 4-2. RP-1009I illuminated keypads have a white wire with a black stripe that is connected to Terminal 45.

**CAUTION:** Avoid splashing solder onto the keypad circuit board. Solder splashes are the most common cause of keypad malfunction.

To cause the control center to come back armed after a power loss, short keyswitch Terminals 10 and 11 and do *not* use keyswitches. The fallback code (PROM locations 249-252) must then be used to disarm the control center after ac power is restored.

#### (2) Keyswitch Stations

Provide remote arming, LED, digital and Mini-Sounder status indication.

Connect keyswitch stations in parallel, to the terminals shown in Fig. 4-2.

*Keyswitches must be obtained separately*

10 (+), 11 (-)

#### Momentary Keyswitches

Wire optional momentary keyswitches in parallel with these terminals.

*Do not use maintained keyswitches.*

**Tamper  
Switches**

Optional. Tamper switches guard against removal of the control-center cabinet from the wall and/or opening of the control-center door.

If used, tamper switches should, ideally, be connected to a 24-Hour Zone (PROM locations 207-208). See Protective Zones description to select tamper zone.

Wire normally-closed switches in parallel. Wire TPS-2 (normally-open) switches in series. There are two locations in the cabinet for mounting tamper switches:

(a) For protection against removal of the cabinet from the wall, on the left side of the cabinet, there are three mounting holes and an adjacent hole on the back that allows the tamper switch button to contact the wall.

(b) To cause an alarm if the cabinet door is opened, on the right side of the cabinet there are three more mounting holes. A tamper switch mounted on the right would have its button positioned so that it made contact with the closed door.

**NOTE:** If securing the cabinet door against tampering, advise the user and service person that opening the cabinet door will cause a tamper alarm.

11 to 29

### Protective Zones

See the Features list (Chapter 1) and the Glossary (Chapter 2) for an explanation of available programmable options. The Installation Record (Fig. 4-1) inside the control-center door indicates which options have been programmed for each zone.

Maximum loop resistance is 300 ohms for each zone (200 ohms for Supervisory Zone without FT279 RELAY).

Loop response times are:

- (a) Burglary Zones, Supervisory (Fire) Zone: 750 milliseconds (recommended for use with magnetic contacts, window foil, etc.) Burglary Zones 1-8 can be changed (PROM locations 225-228) to 50- or 7-millisecond response.
- (b) 24-Hour Auxiliary Zones: 50 milliseconds (for momentary panic buttons and area protection devices such as photo-electric eyes, passive infrareds, floor mats, etc.)
- (c) 7 milliseconds (primarily for window bugs, and to eliminate the need for a pulse extender.)

### End-of-line Resistor Supervision

All zones are end-of-line resistor supervised, and may contain a combination of normally-open and normally-closed contacts. Connect one of the 1000 ohm end-of-line resistors supplied with the control center across the terminals of the last device on each protective circuit, and across the control-center terminals for each zone that is not used.

### 11 (-), 12 (+) Fire (Supervisory) Zone

An Auto-Reset 24-Hour Zone, generally reserved for fire (where permitted by local fire codes), but may be used to monitor such installation conditions as temperature or essential equipment functioning. (See Fig. 4-3a.)

Refer to the KEYPAD OPERATION chapter to monitor and reset zone conditions.

Preprogrammed for steady siren output signal. (See Terminals 42-43.)

### Connecting Fire-Detection Devices:

Use the instructions below and the wiring instructions accompanying separately-purchased fire-detection devices. Connect all fire sensors in parallel, with no branch circuits. The fire circuit may contain powered fire detectors and non-powered heat detectors. **NOTE:** U.L. residential installations using the Supervisory Zone for fire protection must have at least one powered smoke detector installed.

**NOTE:** The zone and powered fire detectors must be reset following a fire alarm with the Key 9. If the alarm does not time out, it is silenced by disarming the control center. (See KEYPAD OPERATION chapter.)

Use Fig. 4-3a to connect fire-detection circuits containing only thermostats.

Power for fire detectors may be supplied from the control center or externally (see Figs. 4-3b and c). Use an FT-279 End-of-Line Relay/Resistor Supervisory Module to monitor the power supply to the detectors. A relay in the FT-279 remains energized while there is power for the detectors. If there is a power loss, the contacts of the relay open and the keypad indicates fire circuit trouble. Do not use the separate 1000-ohm resistor when connecting an FT-279 module.

- If any powered fire detectors used are not self-resetting:
- (1) Connect detectors to Output 2 (Fig. 4-3c). If the detectors are externally powered, (a) cut Jumper B to isolate Output 2; (b) connect the power supply positive lead to Terminal 34 and the positive lead of the last device to Terminal 36. Connect the negative leads to ground (Terminal 37).
  - (2) The Reset Output 2 Devices feature must be programmed (PROM location 189).
  - (3) After steps (1) and (2) are completed, holding down Key 9 will momentarily remove power to the detectors, resetting them.

**NOTE:** When fire detectors are connected to Output 2, Terminals 34-36 may not be used for any other device.

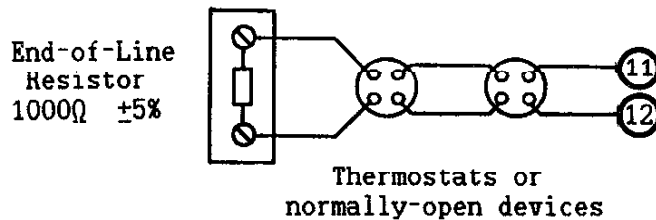

**Fig. 4-3a.** Fire circuit containing only non-powered fire detectors or supervisory circuit with equipment-monitoring devices.

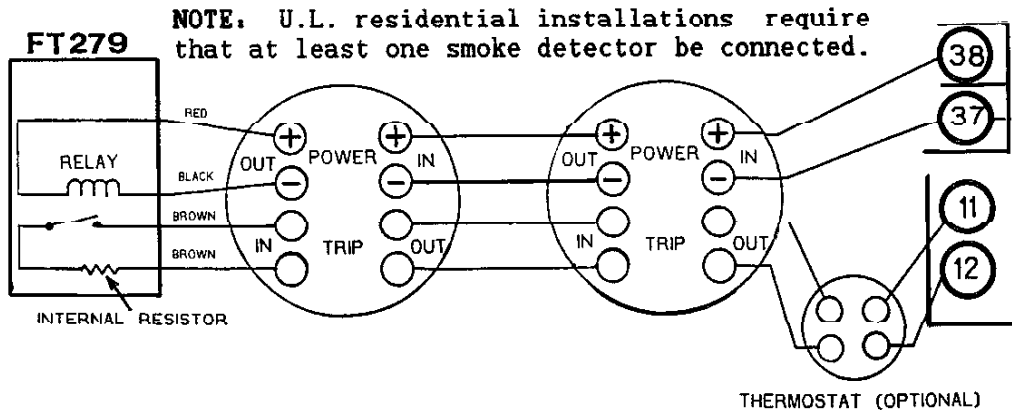

**Fig. 4-3b.** Self-resetting powered smoke detectors. (This example shows detectors powered by the control center.)

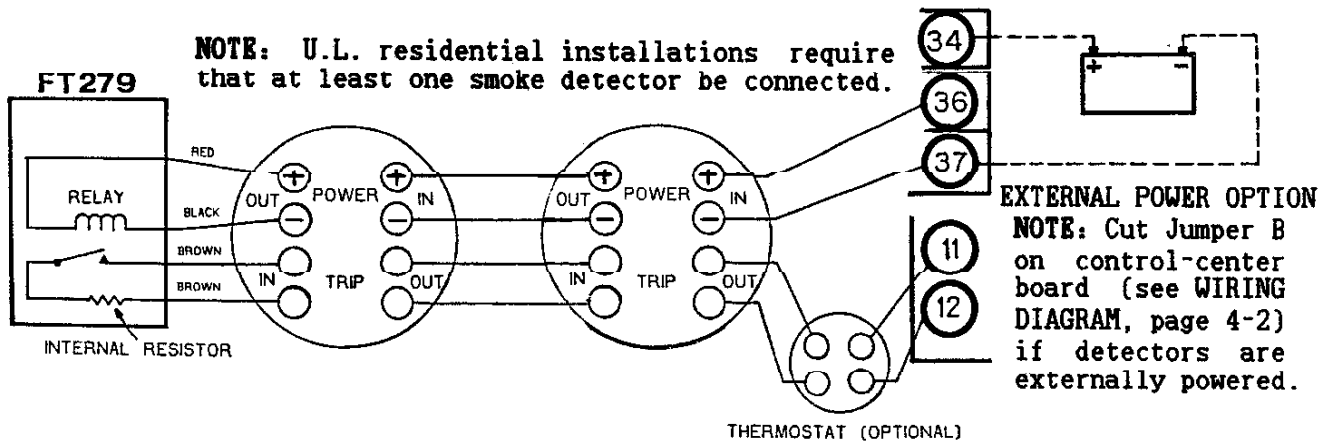

**Fig. 4-3c. Powered smoke detectors reset by the control center.**

<u>Burglary Zones</u>	
13 (+), 14 (-)	Zone 1
14 (-), 15 (+)	Zone 2
16 (+), 17 (-)	Zone 3
17 (-), 18 (+)	Zone 4
19 (+), 20 (-)	Zone 5
20 (-), 21 (+)	Zone 6
22 (+), 23 (-)	Zone 7
23 (-), 24 (+), E8 Lug	Zone 8 or Ac-Failure Detection
25 (+), 26 (-)	Zone 9 - Exit/Entry Zone

Exit/Entry Detection Devices

Connect all exit/entry door detection devices to Zone 9, which is preselected as the Exit/Entry Zone. Zone 9 is an Auto-Reset Zone.

Any of Zones 1 through 8 may be programmed as Exit/Entry Follower Zones (PROM locations 211-212). Detection on Exit/Entry Follower Zones is delayed during the exit and entry periods. Use Exit/Entry Follower Zones for devices that detect across the path between the control center and exit/entry doors.

Day Zone

Any of Burglary Zones 1 to 8 may be programmed to cause Mini-Sounder and digital zone-number indication in the event of open-circuit trouble. See KEYPAD OPERATION chapter to turn off indicators and reset trouble zone.

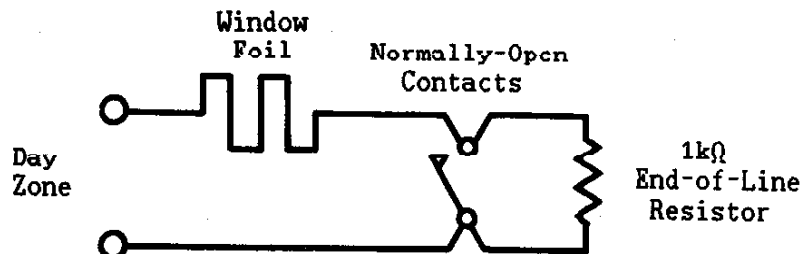

Wire normally-open contacts that are active during the day after the Day-Zone supervised circuits (further down the circuit, as shown in the previous diagram) to prevent bypassing when a window or door is left open. A break in the window foil will cause a Day-Zone indication. The normally-open contacts will only cause the STATUS LED to flash.

E7, E8

#### Ac-Failure Detection

Normally, an ac power loss is indicated after at least 4 hours by a low-battery report. Zone 8 may be dedicated to instant ac power-loss detection, and is then not used for burglary detection.

If the installation requires instant ac power loss detection:

- (1) Connect Lug E7 to Lug E8. (E8 is an input to Zone 8.)
- (2) Connect a 1000 ohm resistor between Terminals 23 and 24.
- (3) Programming is required to obtain a communicator report (locations 014-015, 179) if ac power is lost.
- (4) Abort Delay and 750 millisecond response (preprogrammed) are recommended so that reporting for short power losses may be ignored or aborted.

27 (+), 28 (-) Auxiliary Zone 1

28 (-), 29 (+) Auxiliary Zone 2

Two 24-Hour Auto-Reset Zones.

#### Keypad Panic Alarm

Pressing Keys [\*] and [#] at the same time will cause an alarm on 24-Hour Auxiliary Zone 1. Panic input may also be supplied through any normally-open momentary devices optionally connected to this zone. The alarm may be audible (PROM location 218) and/or silently reported to the central station (PROM locations 180 and 018-019). To disable keypad panic, cut the brown jumper located at the lower end of the keypad circuit board; behind Key [S].

#### Ambush (Holdup) Alarm

24-Hour Auxiliary Zone 2 is prewired for ambush alert (if programmed). If used for ambush, this zone should not be used to signal a local alarm.

30, 31

#### Incoming Telephone Lines

32, 33

#### Internal Telephone

Reporting options and transmission information must be programmed for the communicator to work.

Telephones within the premises are automatically disconnected when an alarm is activated and the line is seized by the communicator.

#### CC-403 Cord Connection Sequence

- (1) Connect a CC-403 cord to the telephone line and internal telephone terminals. (See Fig. 4-2.) Keep telephone wiring away from speaker wires.
- (2) Complete all other installation wiring.
- (3) Power-up system: connect transformer, install battery, push START switch.
- (4) Test local response. (See TESTING PROCEDURE.)
- (5) Connect the CC-403 cord to an RJ31X jack installed by the telephone company.

E3

GSM-400 Ground-Start Module

If the dial tone is not continuously active, ground start is needed to establish dial tone. Refer to the instructions furnished with the GSM-400 module.

M-278 Line-Reversal Module

Used to allow the control center to be monitored by a central station through leased lines. On alarm, the module reverses normal line-voltage polarity.

Connect the M-278 module to Output 1 or Output 2 as shown in the instructions included with the M-278. **NOTE:** Trouble conditions cannot be programmed to activate Output 1 or Output 2, and will not be reported if an M-278 module is used. *The Fire (Supervisory) Zone however, may be connected together with another zone to activate Output 1.*

E5

Listen-In Module

If installation requires a listen-in module, connect the unit to Lug E5. Voltage drops to zero at E5 when the communicator goes off-hook to detect dial tone. When the communicator completes its transmission, voltage at E5 returns to 12 volts and the listen-in module can then take over the telephone line.

34 to 36,  
39 to 40,  
42 to 43,

Alarm Outputs

The MAGNUM ALERT-900 has an integrated siren driver for both burglary and fire alarms and two sets of auxiliary relay contacts, through which the control center may supply power, or which may be isolated by cutting Jumper A or B. Bell output may replace siren speaker output by cutting Jumper E.

Output 1 and Output 2

Possible application examples: As supplied, Outputs 1 and 2 will each deliver 12 volts dc, which may be used to activate auxiliary alarm devices, such as house lights switched on by a heavy-duty relay (Fig. 4-4). Alternatively, either or both outputs might be isolated and used for switching on low-voltage accessories from an external power supply when an alarm occurs. Maximum contact rating is 24Vdc @ 2A (resistive). Combined output current for Outputs 1 and 2 on alarm is 1A maximum.

E12

Output-1 Relay Control

Lug E12 will go to approximately 1Vdc when the Output-1 relay is tripped. This may be used to trip an LW-900 Long-Range Wireless Interface. Or, a relay (400 ohms minimum) may be connected between Lug E12 and AUX (+) if a diode is inserted in series (cathode to E12; anode to relay). The Fire Zone cannot be programmed to activate a relay output, however Lug E12 may be used. Connecting a diode from E9 "FIRE" (cathode) to E12 (anode) will activate the Output-1 relay when the Fire Zone is activated.

E13

Output-2 Relay Control

Lug E13 will go to approximately 1Vdc when the Output-2 relay is tripped. This may be used to trip an LW-900 Long-Range Wireless Interface. Or, a relay (400 ohms minimum) may be connected between Lug E13 and AUX (+) if a diode is inserted series (cathode to E13; anode to relay). E13 may also be used to activate Output 2 by connecting to another lug or source that will go low when activated.

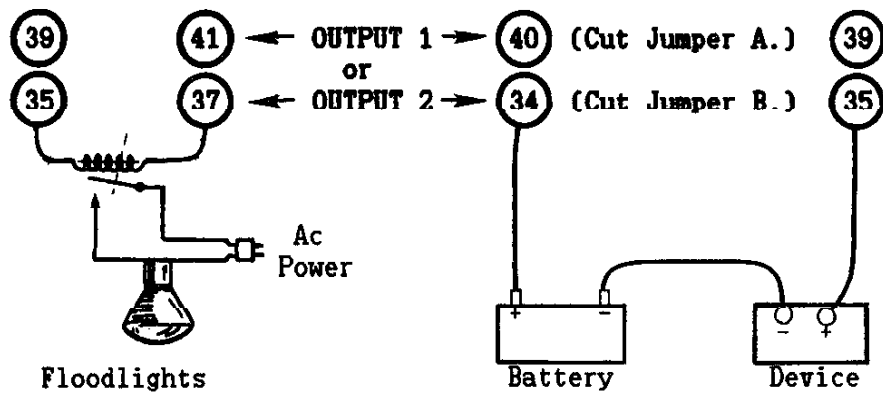

Fig. 4-4a. Relay for switching house lights.

Fig. 4-4b. Externally-powered devices.

39 (+,N/O),  
40 (C),  
Jumper A

Output 1

Program-selected for activation on alarm (PROM locations 219-221), and alarm time-out (locations 235-236).

To activate devices when 12 volts dc is supplied through Output 1, connect the positive lead of first device to Terminal 39 and the negative lead to Terminal 41 (see Fig. 4-4a).

To isolate Output 1 for use with devices powered externally, cut Jumper A. Connect the positive lead of the first device to Terminal 39, the positive lead of the external power supply to Terminal 40, and the negative lead of the device to the power supply negative (-) terminal (see Fig. 4-4b). Devices connected in this way will be activated when the auxiliary contacts on Output 1 close.

Access Control Switch

Connect the door switch to the relay contacts on Output-1 Terminals 39-40. Cut Jumper A to isolate these contacts. Output 1 may not be used to trigger an alarm device when used to release access door.

Install an RP-1009 keypad in a location convenient for entering the access control code. Instruct the user to program an access control code through the keypad, and enter that code to release the door when entry is desired. See Section 3, Hold-Down Function 8 (PROGRAM) to program the access control code.

34 (C),  
35 (+,N/O),  
36 (+,N/C),  
Jumper B

Output 2

Program-selected for activation on alarm (PROM locations 222-224), and alarm time-out (locations 237-238). Where necessary, alarm Output 2 is reserved for resetting latched fire detectors. (See Terminals 11-12: Fire Zone.) If used to reset fire detectors, Output 2 may not be used for any other zone/device.

To activate devices when 12 volts dc is supplied through Output 2, connect the positive lead of the first device to Terminal 35 and the negative lead to Terminal 37 (Fig. 4-4a). To deactivate devices (such as fire detectors) when the 12-volt dc control-center output is removed from Output 2, connect the positive lead of the first device to Terminal 36 and the negative lead to Terminal 37. (See Terminals 11-12: Fire Zone - Fig. 4-3c.)



To isolate Output 2 for use with devices powered externally, cut Jumper B. Connect the positive lead of the external power supply to Terminal 34. To activate devices when the contacts on Output 2 close, connect the positive lead of the device circuit to Terminal 35 (Fig. 4-4b). To deactivate devices when the contacts on Output 2 open, connect the positive lead of the first device to Terminal 36 (Fig. 4-3c).

**42 (+), 43 (-) Speaker/Bell Output**

**E6, Jumper E  
Jumper C**

The siren can be programmed to sound when an alarm occurs on any Burglary Zone or either of the 24-Hour Auxiliary Zones. (PROM locations 216-218; time-out period in locations 233-234.) Fire (Supervisory) Zone alarm activation is preprogrammed, but the time-out period, if required, must be programmed (locations 239-240). The siren signal sweeps for burglary and sounds steadily for fire. Cutting Jumper C will disable the fire (supervisory) alarm.

Siren speakers are purchased separately. To obtain an audible siren alarm, connect an 8-ohm/15-watt speaker or two 8-ohm/15-watt speakers wired in parallel across Terminals 42-43.

To connect a bell to Terminals 42-43, cut Jumper E (labelled "cut for bell") and use a PROM programmed for pulsing supervisory alarm ("1" in location 189).

To obtain siren supervision, connect Lug E6 to an open-circuit Day Supervision Zone (locations 194-195). The keypad will indicate if either the circuit at Terminals 42-43 or the speaker output fuse F101 opens.

**37 (-), 38 (+) Constant Auxiliary Output**

These terminals connect to the internal control-center power supply that delivers continuous, fused, regulated auxiliary output voltage of approximately 12 volts dc. Note that the total combined standby output (Remote Power, Constant Auxiliary Power, and Output 2) is 800mA maximum.

This output may be used to power photoelectric, passive infrared, ultrasonic or other 12-volt dc moderate-current detection devices.

If latching alarm devices are powered by this auxiliary output, wire a momentary normally-closed switch in series with Terminal 38 and the first device. Use this switch to reset the devices when latched in alarm.

**44, 45**

**Ac Power**

To supply ac operating power to the control center, connect the TRF-11 16.5Vac, 40VA, Class-2 stepdown transformer. *Use of any transformer other than the TRF-11 may result in damage or improper operation of the control center.*

The transformer must be plugged into an outlet that provides 24-hour continuous power. One of the most common causes of false alarms is the use of outlets that are switched off at the end of the day with a common circuit breaker.

If central station reporting is required for ac power loss detection, Zone 8 is used. (See Burglary Zones: Ac-Failure Detection.)

**Caution:** The TRF-11 contains an internal non-replaceable fuse that will blow on any momentary short. Do not attempt to check its operation by shorting the output and looking for sparks.

## Battery Leads Standby Battery

Standby power is supplied by a 12-volt dc, 6AH rechargeable battery. Attach the leads at the lower-right side of the board to the battery, observing polarity: red (+); black (-).

Maximum operating time after an ac power loss with the recommended standby battery is at least 4 hours. In areas where power outages are frequent or long, a second standby of the same type (sealed lead-acid) battery may also be used. Harness RBAT-H1 permits the parallel connection of two batteries.

Use the Key 1 weekly to test the condition of the battery. (See KEYPAD OPERATION.)

E4

### Arm Lug

This point will go to 0Vdc when the system is armed. This may be used with external equipment such as an SG-1930 Shock Guard Processor. (Refer to Shock Guard instructions.)

E9, E10

### Fire, Burglary Lugs

Lug E9 or E10 will go to approximately 1Vdc when a fire or burglary alarm (respectively) is tripped. Either may be used to trip an LW-900 Long-Range Wireless Interface. Or, a relay (400 ohms min.) may be connected between either lug and AUX (+) if a diode is wired in series (cathode to E9/E10; anode to relay).

E11

### Low-Battery Lug

This lug will go to 0Vdc if a low-battery condition exists. It may be used to trip an LW-900 Long-Range Wireless Interface.

Fuses **WARNING:** For continued protection against risk of fire, replace any fuse, if necessary, only with one of the same type and rating (described below).

F1

### Output 1/Siren Driver Fuse (5A)

Protects the Output-1 relay contacts at Terminals 39-40 and the internal siren driver circuitry. If blown or removed, the devices on Terminals 39-40 and the siren/ bell will not operate when an alarm occurs on a zone selected to activate them.

F2

### Auxiliary Power/Output 2 Fuse (3A)

Protects the regulated dc auxiliary output and the auxiliary relay contacts on Output 2, Terminals 34-36.

If this fuse is blown or removed, the following occur:

- (1) Power is removed from Output 2. If the fire detector circuit is connected to this output, the Fire (Supervisory) Zone will not be protected.
- (2) Power is removed from the Constant Auxiliary Output Terminals 37-38. It is suggested that any sensors connected to these terminals include relays that will cause an alarm condition if power is lost.

F3

### Remote Power Fuse (1A)

This 1AG fuse protects the keypad and sounder.

F101

### Siren/Bell Fuse (3A)

Protects the siren alarm output at Terminals 42-43. If blown or removed, the siren will not operate in the event of a fire alarm, or an alarm on one of the zones selected to sound the burglary siren. **NOTE:** Lug 6 may be used to supervise this condition. See Terminals 42-43: Speaker.

## SPECIFICATIONS

Operating Temperature	0 - 49°C
Input Power	16.5Vac, 40VA, Class-2 transformer
Loop Voltage	10 to 13Vdc
Loop Current	5.5mA (normal resistance)
Zone Resistance	300 ohms maximum series resistance per loop (200 ohms on Supervisory Zone without FT-279 relay.)
Alarm Outputs	
Siren/Bell Output	Selectable for speaker or bell Siren output: 15W, 8 ohms; 30W, 4 ohms Bell: 12Vdc bell, 2.0A maximum
Relay Outputs 1 and 2	Selectable for 12Vdc or isolated contacts
Relay Contact Ratings	24Vdc, 2A (resistive)
Output 1 Current	1.0A maximum (Alarm only)
Output 2 Current	(see Combined Standby Current)
Auxiliary Output	12Vdc regulated (see Combined Standby Current)
Remote Station	
Current	50mA (standby), 80mA (alarm)
Maximum number of stations	10
Mini-Sounder	10mA
Control Center Current	250mA (standby),
Combined Standby Current	(Remote Power; Aux. Output; Output 2 in Standby or Alarm), 800mA max.; 1.5A with 2 batteries
Battery	6AH rechargeable, sealed lead acid, RBAT-6
Fuses	
F1, Output 1/Siren Driver	5A, 3AG
F2, Auxiliary Power/Output 2	3A, 3AG
F3, Remote Power	1A, 1AG
F101, Speaker/Bell	3A, 3AG
Housing Dimensions	13-5/16"H x 13-1/4"W x 3-7/8"D
Shipping Weight	16-3/4 lbs (Approximately)
<u>For Canadian Model Only:</u>	
Load Number*	6
CSA-Approved Power Supply	Magnetic Coil Model MG1640-D2

\*The "Load Number" denotes the percentage of the total load allowed to be connected to a telephone loop that is used by the device. The termination on a loop may consist of any combination of devices subject only to the requirement that the total of the Load Numbers of all devices does not exceed 100.

## POWER-UP SEQUENCE

- (1) Insert PROM into socket on circuit board *before connecting power*.
- (2) Connect ac power.
- (3) Install standby battery.  
**NOTE:** If the cabinet door is protected by a tamper switch, leave the cabinet open until testing is completed.
- (4) Push START switch at upper-left corner of circuit board.
- (5) Complete Testing Procedure Steps (A) through (C).
- (6) Connect CC-403 telephone cord to RJ31X jack. Complete communicator test, Step (D).

## TESTING PROCEDURE

Read KEYPAD OPERATION (Chapter 3) before testing.

If testing indicates problems, see KEYPAD OPERATION and the Troubleshooting Guide at the end of this chapter.

### (A) Load Codes Through Keypad:

- (1) Hold down Key 8 until the Mini-Sounder beeps. Within 8 seconds, enter the keypad program code.

*Exception:* High-security keypad programming may be enabled (by an 8 in PROM location 189). Push the START switch at the upper-left corner of the control center circuit board, then hold down Key 8 until the Mini-Sounder beeps. After the beep, enter the keypad programming code.

- (2) Press [S], then [1], then four digits for the first arm/disarm code.
- (3) If access through entry door must be from inside while the premises is occupied, press [S], then [9], then enter a two- to four-digit access control code.
- (4) Press [S] twice to end the keypad programming session.

### (B) Check Keypad Indication:

- (1) While disarmed,
  - (a) Check battery: Hold down Key 1 until the burglary alarm sounds.
  - (b) Check for zone continuity and swingers. Use Key 7 (Fault Find).
  - (c) Test Day Zone (if programmed):  
Cause open- or short-circuit condition on Day Zone; green STATUS LED should flash rapidly and zone number should appear on digital display. Hold down Key 9 to turn off indicators. Restore zone.
  - (d) Test fire (supervisory) trouble: Loosen wire on Fire (Supervisory) Zone terminal. *Wait 10 seconds.* Bottom red LED should blink and Mini-Sounder should pulse. Hold down Key 9 to silence sounder. Restore zone.
  - (e) Test Auto-Shunt: Cause trouble on a Burglary Zone. (For example, open a window.) Green STATUS LED will blink on momentarily every second when trouble exists. Hold down Key 3 for digital display of trouble zone numbers. Do not repair trouble condition.
  - (f) Check Ac-Fail indication: Disconnect transformer. Top three LEDs should flash together. Hold down Key 9 to allow arming without ac power or reconnect transformer.
- (2) Arm with arming code: Mini-Sounder should sound 1 second and red ARMED LED should go on to indicate that a zone is auto-shunted.
- (3) Open and close exit/entry door. Wait for end of exit delay period. Open exit/entry door. Mini-Sounder should signal steadily. Disarm with code.
- (4) If transformer is disconnected, reconnect it. Remove trouble from zone that auto-shunted. Restore all zones. Arm and disarm again to reset any zones that are not programmed for Auto-Reset.

### (C) Test Arming For Occupied Premises:

- (1) Manually shunt (if programmed):
  - (a) Press Key [S], then the number of a selective-shunt zone.
  - (b) Press Key [S] twice to test group shunt.
  - (c) Hold down Key 2 for digital display of manually-shunted zone numbers.
- (2) If access control switch installed, have authorized user enter using the access control code.
- (3) Cancel exit/entry delay: Hold down Key 4 until Mini-Sounder beeps.

- (4) Arm:
  - (a) Enter code within 8 seconds.
  - (b) Trigger a detection device on a manually-shunted zone to ensure that alarm does not sound.
  - (c) Open exit/entry door. The alarm should sound.
- (5) Disarm. This will cancel all manual shunts.
- (D) Test Local and Communicator Alarm Response:
  - (1) Call the central station and advise that a test is in progress. Verify that receiver is operating.
  - (2) While disarmed:
    - (a) Connect CC-403 cord to RJ31X jack.
    - (b) Hold down Key 6 (if programmed). Wait for steady Mini-Sounder signal to go off, indicating that the communicator detected a dial tone.
  - (3) Arm. Wait for ringback verification of closing report (if programmed).
  - (4) Verify exit/entry follower devices (if programmed) delay after arming and through exit period. Walk to exit door; open and close door. Be sure that no alarm sounds.
  - (5) Test Burglary Zones: Cross paths of detectors; open and close windows; verify that all local alarm devices programmed for each zone respond.
  - (6) Check alarm-memory indication: Red keypad ALARM LED should flash and tripped Burglary Zone numbers should be displayed on digital readout. Press Key 3 to display any 24-Hour Zones still in fault condition.
  - (7) Test Fire (Supervisory) Zone:
    - (a) Use instructions supplied with detector (or monitored equipment) to momentarily trigger an alarm.
    - (b) Verify that local alarm sounds.
    - (c) Verify that bottom red keypad (FIRE/TROUBLE) LED lights steadily and that Mini-Sounder pulses; hold down Key 9 to silence sounder.
    - (d) Wait 8 seconds for device to clear. Hold down Key 9 to reset. If alarm does not time out, disarm control center to silence, then rearm to continue testing.
  - (8) Test tamper alarm (if installed): Close, then open control center door; verify local alarm response. Close cabinet door. Disarm (if necessary) to silence alarm, and rearm to continue testing.
  - (9) Test keypad-panic alarm: Press keypad [\*] and [#] buttons at the same time; verify local alarm.
  - (10) Disarm and (if programmed) test ambush alarm: Enter ambush code. Enter disarm code. No local alarm should sound.
  - (11) Verify reporting: Call central station to determine that appropriate programmed alarm, restore and opening reports were received.

#### FAMILIARIZING THE END-USER WITH THE SYSTEM

- (A) Complete the Alarm Plan in the User's Manual and use it to explain zone coverages. Show which are Priority, Auto- and Manual-Shunt Zones.
- (B) Advise the user to read the KEYPAD OPERATION chapter.
  - (1) Help the user practice loading arming and access codes.
  - (2) Demonstrate Daily Operation procedures. Use keypad indicators and hold-down functions. Explain the operation of 24-Hour Zones.
  - (3) Practice keypad battery and communicator confidence tests. Advise the user to test the battery weekly.
- (C) Demonstrate fire-circuit operation:
  - (1) Indicate the need to prepare and rehearse an escape plan.
  - (2) Demonstrate resetting fire detectors with Key 9, and silencing alarm by arming/disarming.

## WIRING TROUBLESHOOTING GUIDE

Use this guide and the KEYPAD OPERATION section for wiring and operation problems. Where programming causes are indicated, specific programming remedies are provided in the separate Programming Troubleshooting Guide, following the Glossary and PROM PROGRAMMING INFORMATION in Chapter 2.

**NOTE:** If the control center has tamper protection on a zone programmed to report, alert the central station before opening the cabinet door.

**SYMPTOM: ANY KEYPAD FAILURE. FOR EXAMPLE, INDICATORS OR ARM/DISARM CIRCUIT DO NOT WORK PROPERLY**

### POSSIBLE CAUSE

#### REMEDY

Solder Splashes.

- Check for solder splashes on keypad circuit board. Solder splashes are the most common cause of keypad malfunction. Carefully remove excess solder.

Faulty Wiring.

- Check connections to Terminals 1-9.

**SYMPTOM: NO RED ARMED OR GREEN STATUS LED AFTER POWER-UP**

### POSSIBLE CAUSE

#### REMEDY

Wrong Ac Input Voltage.

- If voltage at Terminals 44 and 45 is not 16 to 18Vac, check wiring from transformer to these terminals.
- If output voltage at transformer terminals is not 16-18Vac, replace transformer.

Blown Power Fuse (F2).

- Replace.

Faulty Keypad or Keyswitch Station.

- Try another arming unit.

**SYMPTOM: USER CANNOT PROGRAM ARM/DISARM CODES FROM KEYPAD**

### POSSIBLE CAUSE

#### REMEDY

Normal Operation for High-Security Installations.

- Press START switch at upper-left corner of control-center circuit board. Hold down Key 8 until the Mini-Sounder beeps. Enter the keypad program authorization code, and choose arm/disarm and access control codes.

**Warning:** Opening cabinet door may cause a tamper alarm.

**SYMPTOM: CANNOT ARM OR DISARM**

POSSIBLE CAUSE

REMEDY

Incorrect Code Entry.

- Wait 2 seconds. Try to arm or disarm again.

No Arm/Disarm Code.

- Following a power loss, or when START switch on control-center circuit board is pressed, arm/disarm and access control codes may be erased. To arm/disarm, use fallback code (if available) or reload codes. To reload codes,
  - (1) If necessary, press START switch.
  - (2) Hold down Key 8.
  - (3) Enter the keypad program code.
  - (4) Reenter all arm/disarm codes and access control code.

Code Keys or Keyswitch Not Properly Connected.

- Check wiring to Terminals 1 through 4 (keypad) or 10 and 11 (key-switch).

Short or Open Circuit.

- Check wiring to Terminals 1 through 4.

Faulty Keypad or Keyswitch Station.

- Try another arming unit.

**SYMPTOM: NO ALARM LED OR DIGITAL DISPLAY ON ALARM WHEN ARMED**

POSSIBLE CAUSE

REMEDY

24-Hour Zone In Alarm.

- Normal operation. Alarms on 24-Hour Zones are not indicated at the keypad. To locate problems on any 24-Hour Zones 1-8, hold down Key 3. Alarms on the Fire (Supervisory) Zone indicate on the bottom red FIRE/TROUBLE LED.

**SYMPTOM: YELLOW LED DOES NOT GO ON WHEN [S] (SHUNT) BUTTON AND ZONE NUMBERS PRESSED, OR ZONE NUMBERS DO NOT DISPLAY WHEN KEY [2] PRESSED**

POSSIBLE CAUSE

REMEDY

Zones Not Programmed for Manual Shunt.

- Obtain correctly-programmed PROM.

**SYMPTOM: OPENING EXIT/ENTRY DOOR CAUSES AN ALARM**

POSSIBLE CAUSE

REMEDY

Exit/Entry Delays Cancelled.

- Key 4 has been pressed. Disarm and arm again.

Communicator, Telephone Lines or Central-Station Receiver Not Working.

- If programmed to start exit delay after closing ringback, and central station does not verify closing report:

- (1) Disarm.
- (2) If programmed, hold down Key 6 to check dial-tone detection.
- (3) Call central station to check condition of receiver.
- (4) Arm and hold down Key 5 to manually start exit delay.

Programming Error.

- Exit delay programmed to start after closing ringback, but closing report is not programmed. Obtain correctly-programmed PROM.

**SYMPTOM: PANIC ZONE CANNOT BE ACTIVATED FROM KEYPAD**

POSSIBLE CAUSE

REMEDY

Panic Buttons Incorrectly Pressed.

- Push [\*] and [#] keys at the same time.

Brown Jumper Cut (lower end of keypad circuit board, behind Key [S]).

- Repair jumper.

**SYMPTOM: SOUNDER GOES ON WHEN ARMING**

POSSIBLE CAUSE

REMEDY

Normal Operation (a zone is being auto-shunted).

- Repair zone as soon as possible.

Low-Battery Condition.

- Recharge or replace battery.

Priority Condition. (Priority Zone in trouble; alarm memory not reset, ac failure not bypassed).

- If "0" is displayed, disarm. Repair any Priority-Zone fault condition. If ac-failure condition exists, hold down Key 9 until sounder beeps, then arm.

Programming Error.

- Obtain correctly-programmed PROM.



**SYMPTOM: ZONE VIOLATED, FAILS TO TRIP, PANEL ARMED**

POSSIBLE CAUSE

REMEDY

Grounded Loop.

- Arm. Remove wire from negative zone terminal. If zone still does not trip, remove wire from positive zone terminal. If control center now goes into alarm. locate ground on loop.

**SYMPTOM: ALARM OUTPUT DEVICE DOES NOT GO ON WHEN ZONE TRIPPED**

POSSIBLE CAUSE

REMEDY

Wiring Problem.

- Check that speaker or bell is connected to Terminals 42-43. If using bell on these terminals, check that Jumper E has been cut.
- If zone uses Output 2 (Terminals 35 and 37 or 34 and 35) or Output 1 (Terminals 39 and 41 or 39 and 40), check for device connected to these contacts.
- Check for loose wires, opens or shorts in wiring to all alarm output terminals.

Jumper A or B Cut for Device Without Self-Contained Power Supply.

- Reconnect jumper.

Power Loss.

- Check that transformer is plugged into a continuous ac power source. Measure the voltage across the battery connecting leads; it should be approximately 13.8Vdc.

Faulty Battery or Battery Connections.

- Check that red lead from circuit board is connected to (+) terminal of battery, and black lead to (-) terminal.
- Hold down Key 1 to check battery for discharged condition or defect.
- Disconnect battery. If battery terminal voltage is not 13 to 14Vdc and battery cannot be fully charged within approximately 1 day, it is defective.

Fuse Blown.

- If siren/bell does not sound, check speaker output (F101) and siren driver (F1) fuses. If device on Output 1 (Terminals 39-40), check Output 1 (F1) fuse. Check for short circuit on alarm device.
- If device connected to Output 2 (Terminals 34-37) check 3A power fuse (F2). Check for short circuit on Auxiliary Output Terminals 37-38.

Alarm Output Programming Error.

- Obtain PROM with programming of alarm outputs matching terminals used.

**SYMPTOM: ALARM DOES NOT TIME OUT**

POSSIBLE CAUSE  
REMEDY

Time-Out Period Not Programmed for Alarm Output.

- Obtain correctly-programmed PROM.

**SYMPTOM: FIRE ALARM INDICATION DOES NOT CLEAR**

POSSIBLE CAUSE  
REMEDY

Detectors Not Cleared of Smoke.

- Hold down Key 9 every 8 seconds until detectors clear. Bottom red FIRE/TROUBLE LED will go off when detectors reset.

Detectors Not Self-Resetting and Not Connected to Output 2.

- If powered by control center, connect positive lead of first detector to Terminal 36 (N/C) and negative lead to Terminal 37.  
If externally powered,  
(1) Connect power-supply positive to Terminal 34.  
(2) Connect power-supply negative and negative lead of device to Terminal 37.  
(3) Cut Jumper B.

Detectors Connected to Output 2 but Reset Output 2 Devices Not Programmed.

- Obtain correctly-programmed PROM.

**SYMPTOM: COMMUNICATOR LED\* DOES NOT GO ON (RELAY DOES NOT ENGAGE) TO INDICATE AN ALARM REPORT**

POSSIBLE CAUSE  
REMEDY

Zone Not Programmed to Report On Alarm/Trouble or Device Reacts Too Quickly for Programmed Loop-Response Time.

- Obtain correctly-programmed PROM.

\*The communicator LED is located near the middle of the control-center board.

**SYMPTOM: COMMUNICATOR LED\* GOES ON (RELAY ENGAGES) BUT FAILS TO BLINK (ROTARY DIAL) OR LIGHT STEADILY LONGER THAN 12 SECONDS (TOUCH-TONE DIAL)**

POSSIBLE CAUSE

REMEDY

Wiring Problem at Terminal

- Disconnect CC-403 cord from RJ31X jack. Check for loose wires, opens or shorts at Terminals 30 to 33.

Phone Company Wiring Error.

- With CC-403 cord connected and control center disarmed, hold down Key 6. If Mini-Sounder first pulses, then sounds steadily, communicator could not detect dial tone. Attempt to dial out with regular telephone. If telephone cannot dial out, problem is on the phone line. If telephone can dial out, connect handset to Terminals 30 and 31 and dial out over handset. If dial tone is lost, RJ31X wires are reversed.

Programming Error.

- Obtain PROM with correctly-programmed telephone information.

**SYMPTOM: COMMUNICATOR LED\* LIGHTS STEADILY FOR 12 SECONDS, THEN GOES OUT, (REPEATED 3 TIMES) BEFORE BLINKING (ROTARY DIAL) OR LIGHTING STEADILY LONGER THAN 12 SECONDS (TOUCH-TONE DIAL)**

POSSIBLE CAUSE

REMEDY

Ground Start Needed to Establish Dial Tone.

- Where dial tone is not continually active, install GSM-400 Ground-Start Module.

Programming for Dial-Tone Detection or Dial Delay Required.

- Obtain properly-programmed PROM.

**SYMPTOM: COMMUNICATOR LED\* BLINKS (ROTARY DIAL) OR LIGHTS STEADILY FOR MORE THAN 12 SECONDS (TOUCH-TONE DIAL) 9 TIMES, BUT COMMUNICATOR DOES NOT REPORT**

POSSIBLE CAUSE

REMEDY

Programming Error.

- Connect handset to Terminals 30 and 31. Listen to communicator dial. If receiver does not answer, obtain PROM with correct telephone number programmed.
- If communicator does recognize tone (handshake), obtain PROM programmed with correct receiver format for central station.

\*The communicator LED is located near the middle of the control-center board.

**SYMPTOM: COMMUNICATOR SENDS 4 ROUNDS, THEN GOES ON HOOK 9 TIMES**

POSSIBLE CAUSE

REMEDY

Programming Error.

- Consult central station for receiver and data formats. Sum Check data format, when needed, must be programmed. One- or two-digit event codes may be required. If necessary, have programming corrected.
- If data format is okay, obtain PROM with correct receiver format programmed for central station.

**SYMPTOM: RECEIVER OR COMMUNICATOR NOT RECOGNIZING SIGNALS**

POSSIBLE CAUSE

REMEDY

Wrong Receiver Format or Data Format Programmed.

- Obtain PROM programmed with correct receiver and data formats for central station.

**SYMPTOM: COMMUNICATOR SENDS INCORRECT DATA TRANSMISSION**

POSSIBLE CAUSE

REMEDY

Noise on Telephone Line.

- Connect handset to Terminals 30 and 31. Listen for static on line. It may be helpful for a touch-tone installation to use rotary dial after the first dialing attempt. If desired, obtain PROM programmed for Touch-Tone, Rotary Backup feature.

Error in Programming Communicator Transmission Information.

- Obtain correctly-programmed PROM.

**SYMPTOM: ABORT DELAY BEFORE DIAL FAILS**

POSSIBLE CAUSE

REMEDY

Abort Delay Selected on 24-Hour Zone.

- If an alarm remains on a 24-Hour Zone for the duration of the abort-delay period, the communicator will report. The device/zone must be reset before the control center can be reset to abort the report.
- If abort delay is selected and the zone is a 24-Hour Zone, advise subscriber to abort transmission:
  - (1) Restore the device/zone.
  - (2) Disarm the control center (if zone not auto-reset) before the abort-delay period ends.

**SYMPTOM: ZONE DOES NOT REPORT RESTORAL AFTER BEING CLEARED OF ALARM/TROUBLE CONDITION**

POSSIBLE CAUSE

REMEDY

Zone Not Reset.

- If Burglary Zone is not programmed for Auto-Reset, arm/disarm control center to reset. If problem on Fire Zone, use Key 9 to reset.

Non-Auto-Reset Zone Programmed for Control-Center Restoral Report, but Not Zone-Restoral Report.

- Arm/disarm to reset control center. Report will then be sent.
- To obtain report only when zone resets, zone must be programmed for Auto-Reset, Zone-Restoral Report, and Control-Center Restoral Report. If desired, obtain correctly-programmed PROM.

Zone Not Programmed for Any Restoral Reporting.

- Obtain correctly-programmed PROM.

**SYMPTOM: STANDBY BATTERY NOT RECHARGING**

POSSIBLE CAUSE

REMEDY

Power Loss.

- Disarm. If top three keypad LEDs flash Ac-Failure indication:
  - (1) Check that transformer is plugged into a continuous power source.
  - (2) Check for a general ac power outage.

Defective Battery.

- With control center disarmed, hold down Key 1. If alarm is weak or does not sound properly, disconnect battery. If battery voltage is not 13-14 volts, battery should fully recharge after approximately 1 day of charging, otherwise battery is defective.

## KEYPAD MOUNTING

(For mounting onto enclosure door, see **CONTROL-CENTER MOUNTING**).

### Surface Mounting onto a Wall Using an RPB-1

1. Mount the RPB-1 onto the wall using #6 pan head screws. Do not overtighten screws! Uneven walls may distort keypads causing hinged front panels to bind (shim keypad if necessary).
2. Pull wires through the hole in the back or run a cable through the smaller hole in the side. Keypad wires may have to be shortened to fit.
3. Raise the keypad front panel and mount the keypad onto the RPB-1 with the screws provided. Lower the front panel.

### Flush Mounting into a Wall Using the RPB-2

1. Hold the mounting box flush against the wall (with mounting ears toward the wall) and mark around the outside of the box with a pencil.
2. Carefully cut out the hole for the box, insert into the wall, then tighten the mounting screws.
3. Raise the keypad front panel and position the keypad on the RPB-2 box. (Only the RPB-2 may be used; any other double-gang box may be too small.)
4. Use the mounting holes to secure the keypad to the RPB-2 with #6 screws. Then lower the front panel.

RP-1009 Keypad in RPB-2 Double-Gang Box (front panel of keypad omitted for clarity).

\* Use 4 corner holes to mount keypad without a junction box (see text and mounting template).

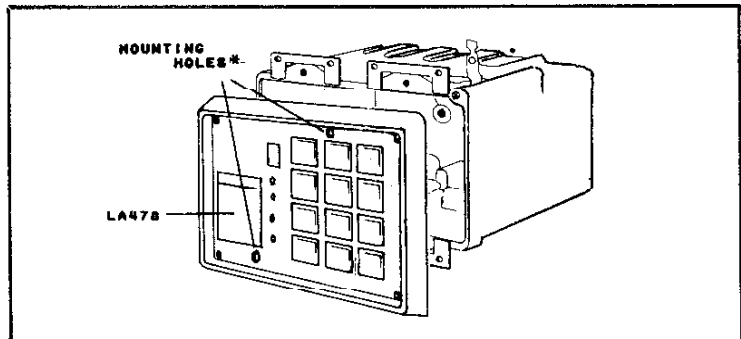

### Flush Mounting Without a Junction Box (see **Mounting Template** on next page.)

1. Pin the template to the wall, or mark through the template onto the wall.
2. Cut carefully around the lines shown. (*Caution: A poorly-cut hole may show after mounting.*)
3. Raise the keypad front panel and screw the keypad onto the wall using the four corner mounting holes (see illustration). Do not overtighten screws! Uneven walls may distort keypad causing front panel to bind (shim keypad if necessary).

### Completing the Installation

1. Complete the Areas of Protection for the respective zones listed on label LA478.
2. Raise the front panel. Affix label LA478 to the keypad subpanel as shown in the illustration.
3. Upon completion, lower the front panel and remove its protective vinyl film covering.

# MOUNTING TEMPLATE

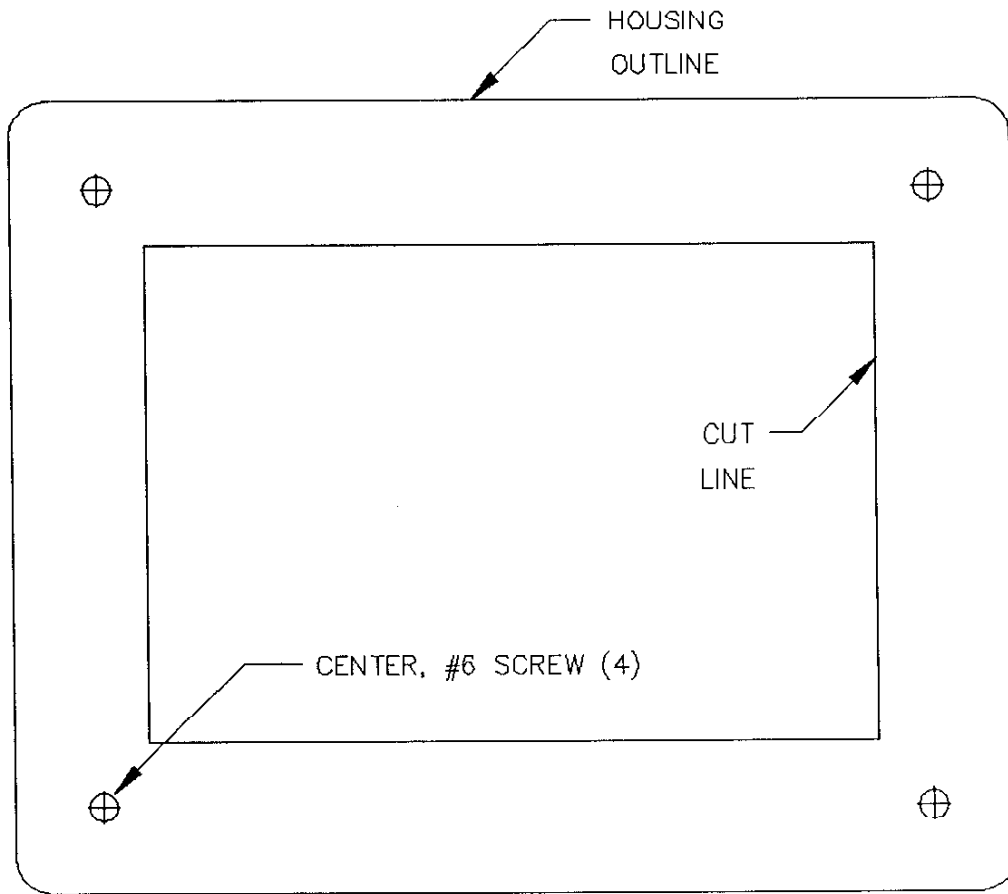

### WIRING LEGEND

**INSTRUCTIONS:** Should removal of the circuit board be necessary, use this wiring legend to relocate leads to their proper terminals. Enter wire identification number or color code in WIRE NUMBER column; enter wire function in DESCRIPTION column (optional).

TERMINAL NUMBER	WIRE NUMBER	DESCRIPTION
1		
2		
3		
4		
5		
6		
7		
8		
9		
10		
11		
12		
13		
14		
15		
16		
17		
18		
19		
20		
21		
22		
23		
24		
25		
26		
27		
28		
29		
30		
31		
32		
33		
34		
35		
36		
37		
38		
39		
40		
41		
42		
43		
44		
45		

**NOTES:**



## INDEX

Abort Delay Before Dial	2-5	Exit/Entry Follower	2-14; 4-6
Ac-Fail Reporting	2-5; 4-7, -10	Extended Format	2-11
Ac Power	4-10	Fallback Code	2-14
Access Control Code	2-15; 3-2, -5; 4-9, -13	Fault Find	3-4, -9
Access Number for Outside Line	2-5	Feature Selection Guide	2-1, -2
Alarm Outputs	2-6; 4-8	Fire (Supervisory) Zone	2-24; 3-5, -9; 4-4
Alarm Time Out	2-7	Fire Detectors	4-4
Alarm/Trouble Codes	2-6, -11, -12, -16, -19	Fire Installation, Typical	4-1
Ambush Code	2-7; 3-8; 4-7	Fire Lug (E9)	4-11
Ambush Zone, see Auxiliary Zone 2	2-24; 4-7	Fire Output Time Out, see Alarm Time Out	2-7
Anti-Jam Time	2-8	FT-279 End-of-Line Relay/Resistor Supervisory Module	4-5
Arm/Disarm Code	2-15; 3-4, -9	Fuses	4-11
Arm Lug (E4)	4-11	Glossary	2-1, -5
Arming Without Ac	2-8; 3-6, -9	Ground Start	4-8
Audible Test On Arming	2-8	Grounding	4-1
Auto-Reset	2-8	Group Shunt, see Manual Shunting	2-16; 3-3
Auto-Reset After Alarm Time Out	2-8	GSR-400 Ground-Start Module	4-8
Auto-Shunt, see Remove Auto-Shunt	2-18	High-Security Keypad Programming	2-15; 3-5, -7; 4-13
Auxiliary Zone 1	2-17, -24; 4-7	Holdup Alarm Report, see Ambush Code	2-7; 4-7
Auxiliary Zone 2	2-8, -24; 4-7	Installation Record	2-2; 4-1
b-F and 10-15, How to Program	2-9	Instant Protection	3-3, -8
Back-Up Reporting	2-9	Isolated (Dry) Contacts	4-8, -9
Battery Leads	4-11	Jumper A	4-9
Burglary Lug (E10)	4-11	Jumper B	4-9
Burglary Output Time Out, see Alarm Time Out	2-7	Jumper C	4-10
CC-403 Card	4-7	Jumper E	2-6; 4-8, -10
Closing Codes	2-9	Keypad	4-3
Closing Report	2-9, -21	Digital Display	3-1, -2
also see Start Exit Delay After Closing Ringback	2-21	Hold-Down Functions	
Communicator Confidence Test	2-10; 3-4	1: Test	3-3
Conditional Closing	2-9	2: Display Shunt	3-3
Conditional Closing Status Report	2-10	3: Display Status	3-3
Conditional Opening Report,		4: Instant Protection	3-3
see Opening Report After Alarm	2-17	5: Start Exit Delay Without Ringback	3-4
Constant Auxiliary Output	4-10	6: Communicator Confidence Test	3-4
Control-Center Restoral Report	2-20	7: Fault Find	3-4
Data Format	2-11	8: Program	3-4, -5
Day Zone	2-12; 3-6, -9; 4-6	9: Reset/Bypass	3-5
Dial Delay	2-5, -13	Keys	3-1, -2
Dial-Tone Detection	2-5, -13; 3-4	LEDs	3-1, -2
Double Reporting	2-13	Mini-Sounder	3-1, -2
E3 (Ground Start)	4-8	Mounting	4-23
E4 (Arm)	4-11	Operation	3-7
E5 (Listen In)	4-8	Keypad Panic	4-7
E6 (Siren Supervision)	4-10	also see Panic Alarm	2-17
E7, E8 (Ac Failure Detection)	4-7	Keypad Program Code	2-15; 3-4, -5
E9 (Fire)	4-11	Keyswitch	4-3
E10 (Burglary)	4-11	Keyswitch Remote Station	4-2, -9
E11 (Low Battery)	4-11	Line Reversal	4-8
E12 (Output 1 Relay Control)	4-8	Listen-In Module, see E5	4-8
E13 (Output 2 Relay Control)	4-8	Loop Response	2-15; 3-4; 4-4
Entry Delay Time	2-14	Low-Battery Lug (E11)	4-11
Exit Delay Time	2-14	Low-Battery Reporting	2-15

A-278 Line-Reversal Module	4-8	Speaker	4-8, -10
Manual Shunting	2-16; 3-3	Speaker/Bell Output	4-10
Mini-Sounder Indication	3-1, -2	Specifications	4-12
Momentary Keyswitch	4-3	Standby Battery	3-3; 4-11
Mounting, Control Center	4-1	Start Exit Delay After Closing Ringback,	2-14, -21; 3-4
Mounting, Keypad	4-23	also see Closing Report	2-9
No Mini-Sounder On Day Zone	2-13	Subscriber Identification Number	2-21
Opening Codes	2-16	Subscriber PROM	2-1
Opening Report	2-16	Sum Check Format	2-12
Opening Report After Alarm	2-17	Supervisory Output Time Out, see Alarm Time Out	2-7
Output 1	4-8, -9	Supervisory Zone	3-5
Output 1 Time Out, see Alarm Time Out	2-7	Swinger Shutdown, see Auto-Reset	2-8
Output 2	2-19; 4-5, -8, -9	Tamper Switches	4-3
Output 2 Time Out, see Alarm Time Out	2-7	Telephone Lines and Phones	4-7
Panic Alarm	2-17	Telephone Number	2-5, -13, -18, -22, -23
also see Keypad Panic Alarm	4-7	Terminal Connections	
Panic Zone, see Auxiliary Zone 1	2-17, -24; 4-7	1- 9: Keypad	4-3
Power-Up Sequence	4-12	10-11: Momentary Keyswitch	4-3
Priority	2-17	11-12: Fire (Supervisory) Zone	4-4
Priority With Bypass	2-16; 3-6	13-26: Burglary Zones	4-6
Program Mode	3-4	27-28: Auxiliary Zone 1	2-17; 4-7
Programming		28-29: Auxiliary Zone 2	2-8; 4-7
Materials	2-1	30-33: Telephone Lines and Phones	4-7
Record Sheet	2-1, -2, -3, -4, -18	34-36: Output 2	2-6, -19; 4-5, -8
Record Sheet Examples	2-30	37-38: Constant Auxiliary Output	4-10
Steps	2-1	39-40: Output 1	4-8
Troubleshooting	2-25	42-43: Siren Speaker	2-6; 4-10
Pulsing Supervisory Alarm, see Alarm Outputs	2-6	44-45: Ac Power	4-10
Receiver Format	2-18	Testing Procedure	4-13
Remote Panic, see Panic Alarm	2-17	Time Selection	2-23
Remove Auto-Shunt	2-18	Touch-Tone Dialing	2-23
Report On Alarm/Trouble	2-19	Troubleshooting Guide,	
Reset	3-5, -6	Wiring	4-15
Reset Output 2 Devices	2-7, -19; 4-5	Programming	2-25
Restoral Report	2-15, -19	Two-Digit Event Code	2-12
Restore Codes	2-19	U.L.-Listed Devices	1-4
RJ1X Jack	4-7	Wiring Troubleshooting Guide	4-15
RP-1009 Keypad	4-2, -3	Zone 9	2-14, -21; 4-6
Selective Shunt, see Manual Shunting	2-16; 3-3	Zone Restoral Report	2-24
Single-Digit Event Code	2-11	24-Hour Protection	2-24

## NOTES

## NAPCO LIMITED WARRANTY

**N**APCO SECURITY SYSTEMS, INC. (NAPCO) warrants its products to be free from manufacturing defects in materials and workmanship for fifteen months following the date of manufacture. NAPCO will, within said period, at its option, repair or replace any product failing to operate correctly without charge to the original purchaser or user.

This warranty shall not apply to any equipment, or any part thereof, which has been repaired by others, improperly installed, improperly used, abused, altered, damaged, subjected to acts of God, or on which any serial numbers have been altered, defaced or removed. Seller will not be responsible for any dismantling or reinstallation charges.

In case of defect, contact the security professional who installed and maintains your security system. NAPCO shall have no obligation under this warranty, or otherwise, if the product has been repaired by others, improperly installed, improperly used, abused, altered, damaged, subjected to accident, nuisance, flood, fire or acts of God, or on which any serial numbers have been altered, defaced or removed. NAPCO will not be responsible for any dismantling, reassembly or reinstallation charges.

In order to exercise the warranty, the product must be returned by the user or purchaser, shipping costs prepaid and insured to NAPCO. After repair or replacement, NAPCO assumes the cost of returning products under warranty.

*There are no warranties, express or implied, which extend beyond the description on the face hereof. There is no express or implied warranty of merchantability or a warranty of fitness for a particular purpose. Additionally, this warranty is in lieu of all other obligations or liabilities on the part of NAPCO.*

Any action for breach of warranty, including but not limited to any implied warranty of merchantability, must be brought within the six months following the end of the warranty period. In no case shall NAPCO be liable to anyone for any consequential or incidental damages for breach of this or any other warranty, express or implied, even if the loss or damage is caused by the seller's own negligence or fault.

*This warranty contains the entire warranty. It is the sole warranty and any prior agreements or representations, whether oral or written, are either merged herein or are expressly cancelled. NAPCO neither assumes, nor authorizes any other person purporting to act on its behalf to modify, to change, or to assume for it, any other warranty or liability concerning its products.*

In no event shall NAPCO be liable for an amount in

excess of NAPCO's original selling price of the product, for any loss or damage, whether direct, indirect, incidental, consequential, or otherwise arising out of any failure of the product. Seller's warranty, as hereinabove set forth, shall not be enlarged, diminished or affected by and no obligation or liability shall arise or grow out of Seller's rendering of technical advice or service in connection with Buyer's order of the goods furnished hereunder.

**NAPCO RECOMMENDS THAT THE ENTIRE SYSTEM BE COMPLETELY TESTED WEEKLY.**

**Warning:** Despite frequent testing, and due to, but not limited to, any or all of the following; criminal tampering, electrical or communications disruption, it is possible for the system to fail to perform as expected. NAPCO does not represent that the product/system may not be compromised or circumvented; or that the product or system will prevent any personal injury or property loss by burglary, robbery, fire or otherwise; nor that the product or system will in all cases provide adequate warning or protection. A properly installed and maintained alarm may only reduce risk of burglary, robbery, fire or otherwise but it is not insurance or a guarantee that these events will not occur. **CONSEQUENTLY, SELLER SHALL HAVE NO LIABILITY FOR ANY PERSONAL INJURY, PROPERTY DAMAGE, OR OTHER LOSS BASED ON A CLAIM THE PRODUCT FAILED TO GIVE WARNING.** Therefore, the installer should in turn advise the consumer to take any and all precautions for his or her safety including, but not limited to, fleeing the premises and calling police or fire department, in order to mitigate the possibilities of harm and/or damage.

NAPCO is not an insurer of either the property or safety of the user's family or employees, and limits its liability for any loss or damage including incidental or consequential damages to NAPCO's original selling price of the product regardless of the cause of such loss or damage. If the user wishes to protect itself to a greater extent, NAPCO will, at user's sole cost and expense, obtain an insurance policy to protect the user, supplemental to user's own policy, at a premium to be determined by NAPCO's insurer upon written notice from user by Certified Mail, Return Receipt Requested, to NAPCO's home office address, and upon payment of the annual premium cost by user.

Some states do not allow limitations on how long an implied Warranty lasts or do not allow the exclusion or limitation of incidental or consequential damages, or differentiate in their treatment of limitations of liability for ordinary or gross negligence, so the above limitations or exclusions may not apply to you. This Warranty gives you specific legal rights and you may also have other rights which vary from state to state.